

Beli Chan

Sales Manager

M: +86 139 2586 8276

WhatsApp: +86 139 2586 8276

E-mail: Beli@championbagmaker.com

MACHINERY MANUFACTURER OF LUXURY PAPER BAGS

CHAMPION MACHINERY MANUFACTURING CO.,LTD.

Add: 42#2and Longyan Industrial Avenue, Humen Town Dongguan City, China PR

Website: www.paper-bag-machine.com

CHAMPION
MACHINERY



Coffee Gong

Sales

M: +86 186 8118 5198

WhatsApp: +86 134 2327 5528

E-mail: sales8@championbagmaker.com

MACHINERY MANUFACTURER OF LUXURY PAPER BAGS

CHAMPION MACHINERY MANUFACTURING CO.,LTD.

Add: 42#2and Longyan Industrial Avenue, Humen Town Dongguan City, China PR

Website: www.paper-bag-machine.com

CHAMPION
MACHINERY

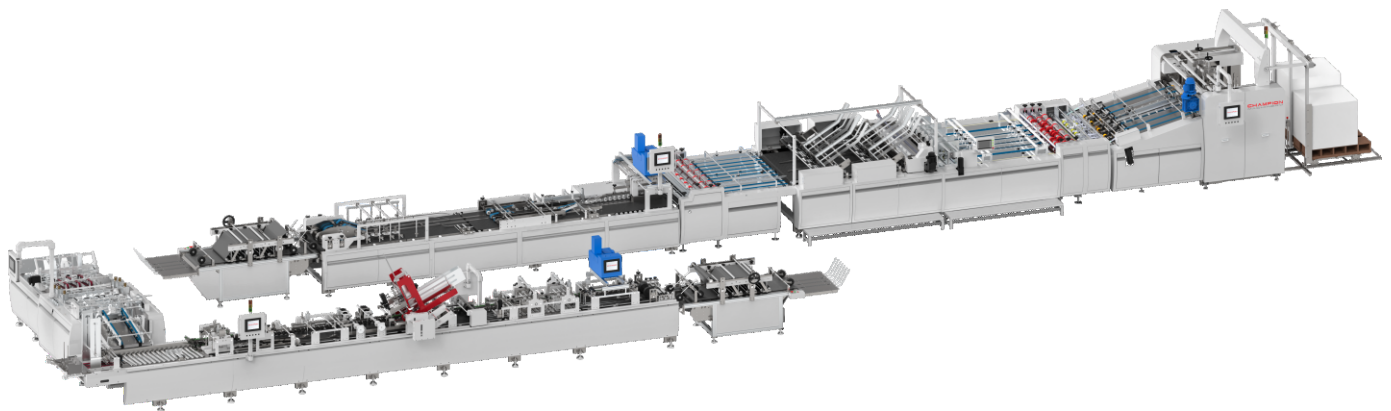

CM2SP-1400TFC/1600TFC CMBF-520A / 600A + CMBS-1000RS

Double Sheets Pasting Paper Bag Machine With Auto 4 PCS Top
Cardboard & Bottom Cardboard Production Line (Group A + B)

双拼纸袋自动头卡底卡生产线组合 A + B

目录

Contents

机器名称图片 Machine Name Image	3
工艺流程图 Process Flowchart	3
机器说明 Machine Description	4
机器特点 Machine Features	4
参数示意图 Sheet Paper Data	5
主要技术参数 Technical Data	6
设备占地规划 Machine Floor Plan	6
核心配件 Core Accessories	7

CM2SP-1400TFC/1600TFC CMBF-520A / 600A + CMBS-1000RS

Double Sheets Pasting Paper Bag Machine With Auto 4 PCS Top Cardboard & Bottom Cardboard Production Line (Group A + B)

双拼纸袋自动头卡底卡生产线组合 A + B

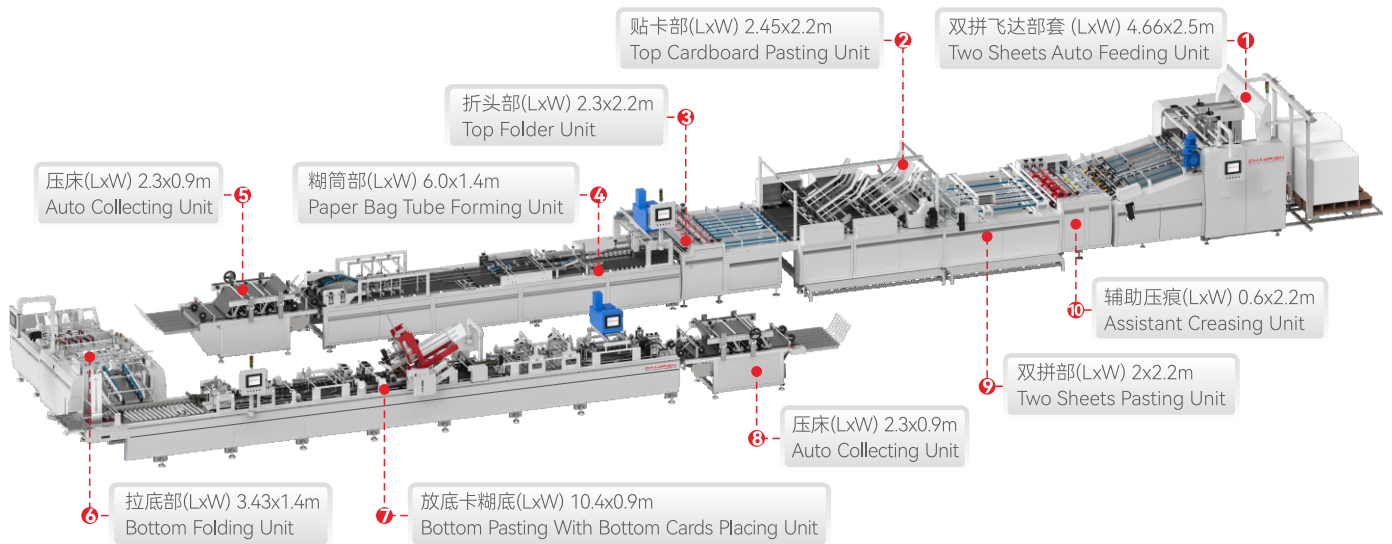

工艺流程图 Process Flowchart

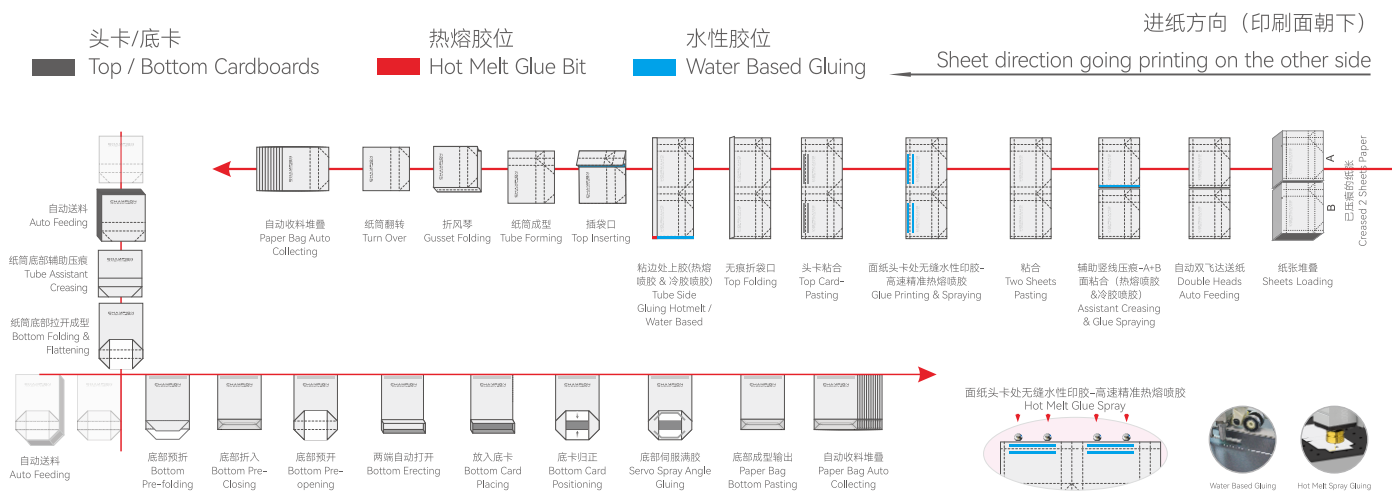



机器说明 Machine Description

该设备采用A+B两条半自动模组线组合的自动双拼纸袋机，是一款集灵活、高效与高度自动化于一体的纸袋生产设备，专为满足双拼纸袋各种工艺生产需求而设计。该设备凭借其广泛的应用领域，如奢侈品、服装、礼品及购物纸袋等，展现了强大的市场适应性。

通过采用双拼成型技术，高速、高精度生产工艺以及智能化控制系统，实现降低成本、提升效率和优化质量。其模块化设计理念使得设备能够灵活应对不同生产需求，同时环保特性也符合当前绿色生产的趋势，成为传统纸袋生产设备升级换代的首选方案。

This automatic double-stitch paper bag machine, combining two semi-automatic modular lines (A+B), combines flexibility, efficiency, and a high degree of automation. Designed to meet the diverse production requirements of double-stitch paper bags, this machine demonstrates strong market adaptability through its wide range of applications, including luxury goods, apparel, gifts, and shopping paper bags.

By utilizing double-stitch forming technology, high-speed, high-precision production processes, and an intelligent control system, the machine reduces costs, improves efficiency, and optimizes quality. Its modular design allows for flexible adaptation to diverse production needs. Its environmentally friendly features align with current trends in green production, making it a leading upgrade option for traditional paper bag production equipment.



机器特点 Machine Features

1. 该生产线生产效率高，调整方便，适用范围广。适用于小、中、大批量或定制化的双页纸袋生产，也适用于对工艺、精度、外观和质量要求较高的高端双拼纸袋，以及结构复杂的双拼/单张送料纸袋的生产；
2. 该生产线的解决方案在一个工位生产纸袋，具有双拼糊合、头卡糊合、折头、贴底卡、袋形成型和底部全涂胶等功能。
3. 高精度、高产量、对操作员经验要求低和低损耗是 CHAMPION 机械设备的显著特点。
4. 根据您的工厂规划，我们提供不同的生产线布局，例如U型、L型或直线（I型）。生产线的功能组合或分离，能应用部分或全部工作。
5. 专门设计的头卡防滑系统，采用热熔胶上胶，确保头卡即时粘在纸张上。同时，卓越的专利水性胶印刷和贴卡系统设计，使顶卡固定精度高且持久耐用。
6. 防卡纸系统设计并配备，可防止生产过程中发生卡纸或连续卡纸。
7. 专利技术，包括防止不停机的不良输出功能，可确保您减少生产损耗和不良停机。目前设计了不良输出、不上胶或自动停机功能，可防止双层送纸、纸张倾斜、顶卡缺失、半边纸缺失、底部加固缺失或放置错误以及制袋卡纸等。
8. 全新人机界面设计和编程，确保您稳定运行生产，快速更换尺寸，让您对投资充满信心。

1. It is widely applicable due to high productivity and easy adjustment. It can be applied to the production of small, medium and large or customized two-sheet paper bags in small, medium or large quantities, and to production of high-end two-sheet paper bags with high requirements for technology, precision, appearance and quality, and two-sheet/sheet-feeding paper bags with complex structures;
2. The solution of this line manufactures the paper bag in 1 station, with functions of two sheets pasting, top card pasting, top folding, bottom reinforcement placing, bag forming and gluing in full pattern of the bottom shape.
3. High precision, high production, Low requirement in operators' experience and low wastage, are well-known features of machines from Champion Machinery.
4. In reference of your work plant plan, we supply different Line layouts, like U shape, L shape, or straight (I) Line. Functions or separations of the line, are supposed to work partially or fully
5. Specifically designed top cards anti-slippery system, applies hot-melt gluing, to ensure the top cards instant stick to the paper. Meanwhile, remarkable patented design of water-based glue printing and card pasting system makes the top cards fixing in high precision and long lasting.
6. Anti-jamming system is designed and equipped, to protect production against jamming or continuous jamming.
7. Patented technology, including NG output against non-stop production, ensures you decrease the wastage of your production, and NG production stop. NG output or non-gluing or auto stop is currently designed against double layer sheets feeding, sheets tilting, top card missing, half side sheet missing, missing or wrongly placed bottom reinforcement, and jamming of bag running ...
8. Fresh operator friendly design and programming, ensure you run production stably, fast in size changing, and confident in investing in your business.



参数示意图 Sheet Paper Data

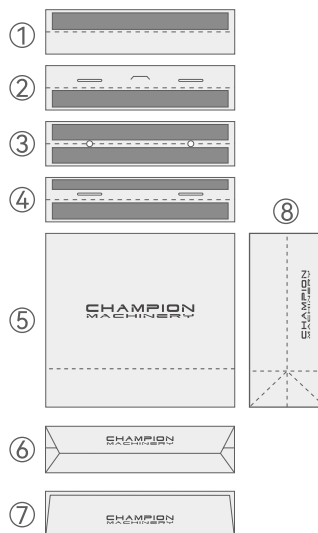
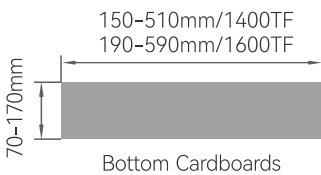
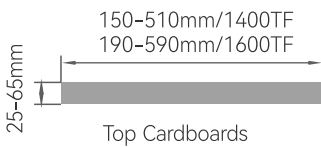
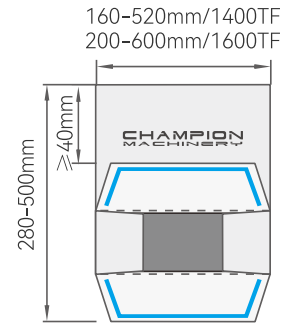
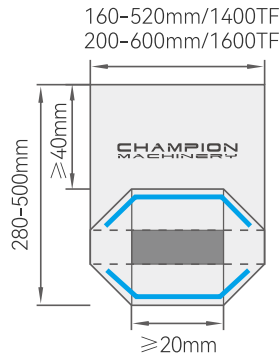
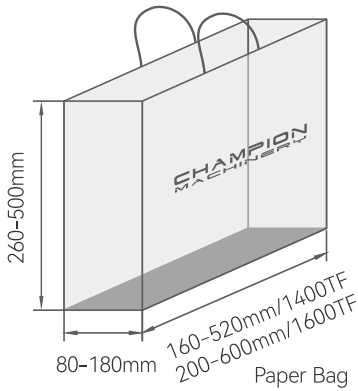
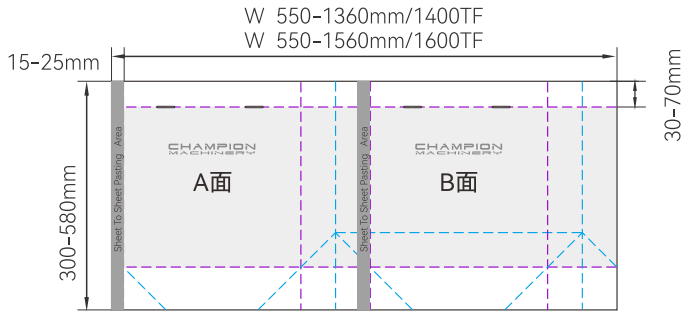
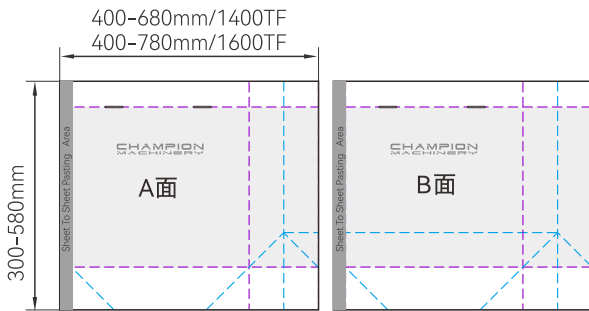
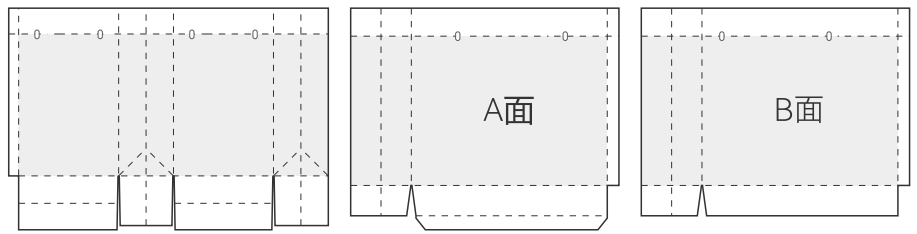
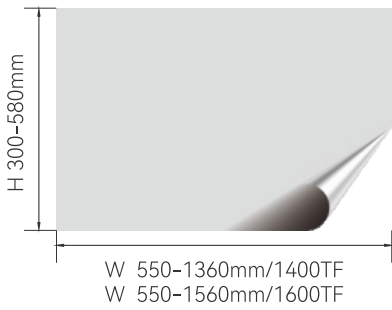

- 1、纸板高于折叠线的位置
Position above top folding line
- 2、纸板位于折叠线以下
Position below top folding line
- 3、顶部粘贴4张相同尺寸的纸板
Top cardboard pasting 4 pcs same size
- 4、顶部粘贴4张不同尺寸的纸板
Top cardboard pasting 4 pcs different size
- 5、纸袋
Paper bag body
- 6、纸袋底型 (1)
Paper bag bottom type
- 7、纸袋底型 (2)
Paper bag bottom type
- 8、纸袋扣板
Paper bag gusset



主要技术参数 TechnicalData

纸张尺寸 Sheet Paper Size		
W进纸宽度范围	Sheet Paper Width	550-1360mm/1400TF 550-1560mm/1600TF
H进纸长度范围	Sheet Paper Length	300-580mm
双拼纸尺寸 Two Sheet Paper Size		
W1进纸宽度范围	Before Pasting Sheet Paper Width 1	400-680mm/1400TF 400-780mm/1600TF
W2进纸宽度范围	Before Pasting Sheet Paper Width 2	400-680mm/1400TF 400-780mm/1600TF
W进纸宽度范围	After Pasted W1+w2 Sheet Paper Width	550-1360mm/1400TF 550-1560mm/1600TF
H进纸长度范围	Sheet Paper Length	300-580mm
纸筒尺寸 Paper Bag Tube Size		
折袋口尺寸	Paper Bag Top Folder Depth	30-70mm
纸筒宽度	Paper Bag Tube Width	160-520mm/1400TF 200-600mm/1600TF
纸筒长度	Paper Bag Tube Length	260-550mm
风琴尺寸	Paper Bag Gusset	80-180mm
粘位尺寸	Sheet Paper Glue Side	15-25mm
适用纸张原材料和耗材 Suitable Paper Material & Glue & Handle		
牛皮纸	Kraft Paper	120-350gsm
铜版纸/覆膜纸	Coat Paper / Laminated	157-250gsm
白卡纸	White Board Paper	157-300gsm
灰板纸	Grey Board Paper	157-300gsm
胶水	Glue	标配热熔选配胶水溶性冷胶 Hot melt glue option water base glue
手提绳	Handle	纸手腕圆/扁, 贴丝带, 打头手提绳子/丝带 其他 Flat paper handle, twisted paper handle, tipping with rope or ribbon handle, Ribbon handles with top cardboard pasting glue fix of luxury paper bag
底卡 Bottom Cardboards		自动 Auto
底卡宽度	Bottom Cardboards Width	70-170mm
底卡长度	Bottom Cardboards Length	150-510mm/1400TF 190-590mm/1600TF
底卡克重	Bottom Cardboards Thickness	200-500gsm
头卡 Top Cardboards		
头卡宽度	Top Cardboards Width	25-65mm
头卡长度	Top Cardboards Length	150-510mm/1400TF 190-590mm/1600TF
头卡克重	Bottom Cardboards Thickness	200-400gsm 4pcs / 200-600gsm 2 pcs
运行 Running		
速度	Speed	0-60 pcs/min
安装要求 Installation		
装机总功率	Total Power Supply	39KW
压缩空气	Compressed Air / Capacity	6bar
储气罐能量	Air Tank Capacity	15m³/h



设备占地规划 Machine Floor Plan

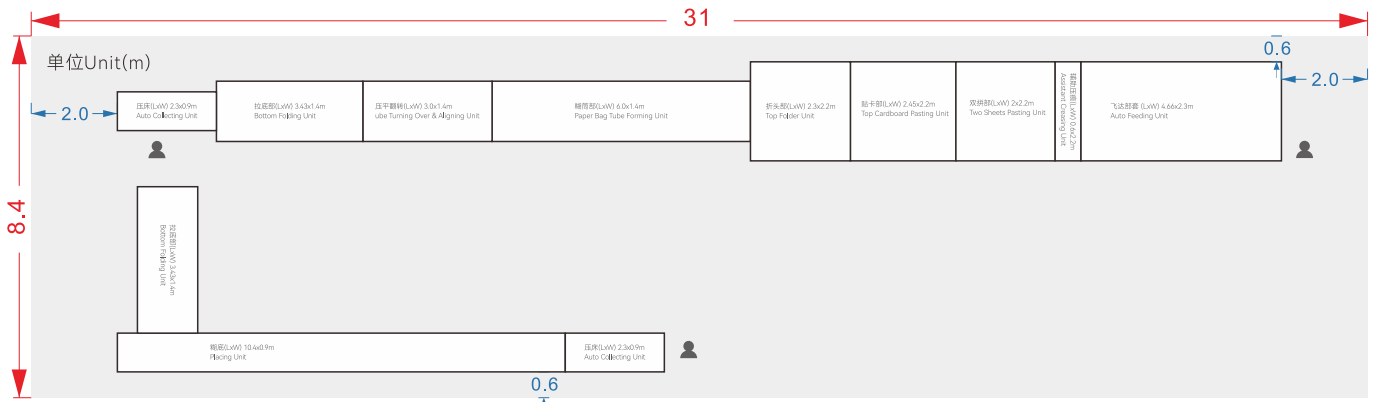



核心配件 Core Accessories



SynMatic

运动控制系统
伺服电机/伺服驱动/变频器
SIMOTION
Servo motor/servo drive/frequency converter

安驰 中国
SynMatic China



KEYENCE

总线控制
BUS CONTROL

基恩士 日本
Keyence Nippon



Honeywell

编码器/接近开关
热过载继电器接触器
ENCODER/PROXIMITY SWITCH
Thermal overload relay contactor

霍尼韦尔 美国
Honeywell US



KEYENCE

主光电眼/光纤
MAIN OPTICAL EYE/FIBER

基恩士 日本
Keyence Nippon



触摸屏
TOUCH SCREEN

威伦 台湾
WEINVIEW Taiwan



MAC

电磁阀
SOLENOID VALVE

MAC 美国
MAC US



CPG

减速机马达
REDUCER MOTOR

晟邦 台湾
Shengbang CPG Taiwan



SIEMENS

主马达
MAIN MOTOR

西门子贝德 德国
Siemens Bader Germany



ORION

真空泵
VACUUM PUMP

好利旺 日本
ORION Japan