

Beli Chan

Sales Manager

M: +86 139 2586 8276

WhatsApp: +86 139 2586 8276

E-mail: Beli@championbagmaker.com

MACHINERY MANUFACTURER OF LUXURY PAPER BAGS

CHAMPION MACHINERY MANUFACTURING CO.,LTD.

Add: 42#2and Longyan Industrial Avenue, Humen Town Dongguan City, China PR

Website: www.paper-bag-machine.com

CHAMPION
MACHINERY



Coffee Gong

Sales

M: +86 186 8118 5198

WhatsApp: +86 134 2327 5528

E-mail: sales8@championbagmaker.com

MACHINERY MANUFACTURER OF LUXURY PAPER BAGS

CHAMPION MACHINERY MANUFACTURING CO.,LTD.

Add: 42#2and Longyan Industrial Avenue, Humen Town Dongguan City, China PR

Website: www.paper-bag-machine.com

CHAMPION
MACHINERY



CMRD-DAE-550

Fully Servo Intelligent TagString-threading Machine For Handbags

全伺服手提袋智能吊牌穿绳机

目录

Contents

机器名称图片 Machine Name Image	3
机器说明 Machine Description	3
机器特点 Machine Features	4
工艺流程图 Process Flowchart	4
原材料 Raw Material	4
绳子样式 Hand Rope Style	5
丝带样式 Ribbon Style	6
支持各种袋底样式 Support Various Bag Bottom Styles	7
颠覆传统，助力更多优势 Disrupting Tradition Fueling More Advantage	7
传统设备升级对比 Comparison Ofconventional Equipment Upgrades	8
主要技术参数 TechnicalData	9
核心配件 Core Accessories	9
设备占地规划 Machine Floor Plan	10



CMRD-DAE-550

Fully Servo Intelligent TagString-threading Machine For Handbags 全伺服手提袋智能吊牌穿绳机



智能
调机
Intelligent
Adjustment

打孔
穿绳
Punching Holes
And Threading
Ropes

打气
眼铁扣
Air Eyelet Iron
Buckle

穿吊
牌功能
Hangtag Function

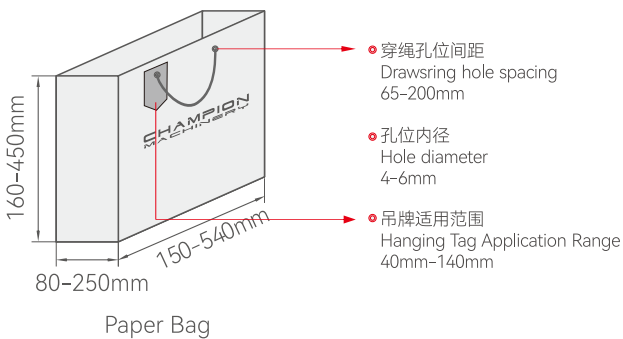

绳材范围 Rope Material

三股绳, 涤纶, 绸缎, 棉绳, 丝带, 低弹力绳, 纸绳等(塑片可制作(鸭舌扣,马蹄口)的材质都可覆盖)

Cotton, Three-stranded rope, Ribbonrope, wrapped with plastic card heads



机器说明 Machine Description

该设备采用全伺服电机驱动的手提袋吊牌穿绳机, 是自动化程度较高的专用设备, 用于为各类手提袋, 自动穿入吊牌和提绳。配合智能控制系统, 实现高精度、高效率的穿绳作业, 适用于大批量生产场景。全自动手提袋穿绳机可实现自动送袋、自动送吊拍、不间断加袋、打气眼铁扣、包塑头、绕线、计数、自动报警等功能。可调节袋的尺寸、高度和孔距。直接节省成本, 提高效率。

This fully servo-driven, specialized bag tag and string-threading machine features a high degree of automation, automatically inserting tags and strings onto various types of bags. Combined with an intelligent control system, it achieves high-precision and efficient string-threading, making it suitable for high-volume production. The fully automatic bag string-threading machine features automatic bag feeding, automatic hanging rack feeding, continuous bag loading, eyelet buckle installation, plastic-wrapped head assembly, string winding, counting, and automatic alarms. Bag size, height, and hole spacing are adjustable, directly saving costs and improving efficiency.



机器特点 Machine Features

- 1.高精度控制:** 采用伺服电机驱动, 定位精度可达±0.1mm, 确保穿绳位置准确无误。
- 2.响应速度快:** 伺服系统动态响应灵敏, 适应高速生产 (如每分钟60-100个袋子)。
- 3.节能高效:** 相比传统气动或机械驱动, 能耗降低30%以上。
- 4.自动供钉:** 振动盘或伺服送钉系统, 缺钉时自动报警。
- 5.自动识别定位:** 通过视觉系统或传感器自动检测袋孔位置, 适应不同袋型。
- 6.智能穿吊牌:** 自动输送吊牌, 智能穿吊牌。
- 7.参数记忆功能:** 可存储多种产品规格参数, 切换生产时一键调用, 减少调试时间。
- 8.故障自诊断:** 实时监测设备状态, 异常时自动报警并提示解决方案 (如断绳、卡袋等)
- 9.连续作业能力:** 配备自动送料、穿绳、出料一体化流程, 减少人工干预。
- 10.人机协作:** 触摸屏界面友好, 支持产量统计、效率分析等数据化管理。
- 11.低噪音运行:** 伺服系统噪音低于70dB, 优于传统机械式设备。
- 12.无油污污染:** 全电动驱动避免气动系统的油雾污染, 符合食品包装卫生要求。

- 1. High-Precision Control:** Driven by a servo motor, positioning accuracy reaches ±0.1mm, ensuring precise string threading.
- 2. Fast Response:** The servo system's dynamic response is sensitive, adaptable to high-speed production (e.g., 60-100 bags per minute).
- 3. Energy-Efficient:** Energy consumption is reduced by over 30% compared to traditional pneumatic or mechanical drives.
- 4. Automatic Nail Feeding:** A vibrating plate or servo-driven nail feeding system automatically alarms when nails are out of stock.
- 5. Automatic Positioning:** A vision system or sensor automatically detects bag hole positions, adapting to different bag shapes.
- 6. Intelligent Hang Tag Insertion:** Automatically feeds and inserts hang tags.
- 7. Parameter Memory:** Stores multiple product specifications and recalls them with a single click when switching production lines, reducing commissioning time.
- 8. Fault Self-Diagnosis:** Real-time monitoring of equipment status, automatic alarms, and solutions for abnormalities (e.g., broken string, stuck bag, etc.).
- 9. Continuous Operation Capability:** Equipped with an integrated automatic feeding, string threading, and unloading process, reducing manual intervention.
- 10. Human-Machine Collaboration:** The user-friendly touchscreen interface supports data-driven management, including production statistics and efficiency analysis.
- 11. Low-Noise Operation:** The servo system produces less than 70dB of noise, outperforming traditional mechanical equipment.
- 12. Oil-Free:** The fully electric drive eliminates oil mist contamination from pneumatic systems, meeting food packaging hygiene requirements.



工艺流程图 Process Flowchart

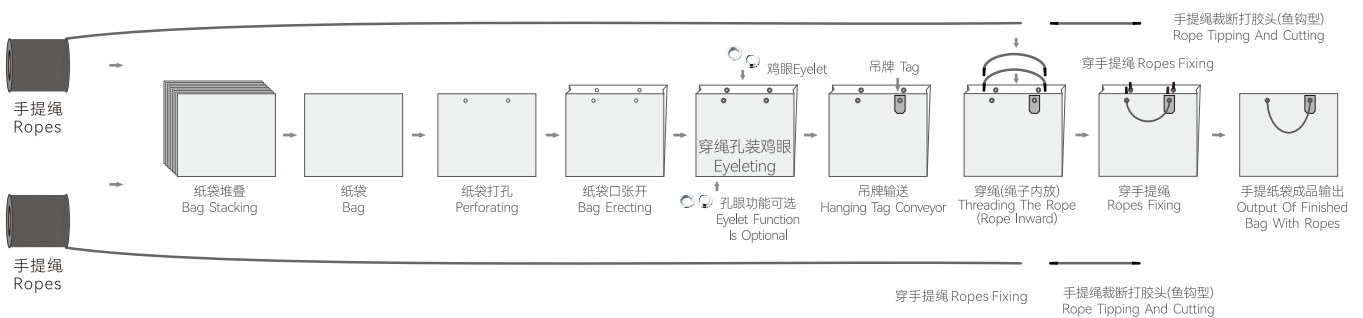

原材料 Raw Material





绳子样式 Hand Rope Style





丝带样式 Ribbon Style

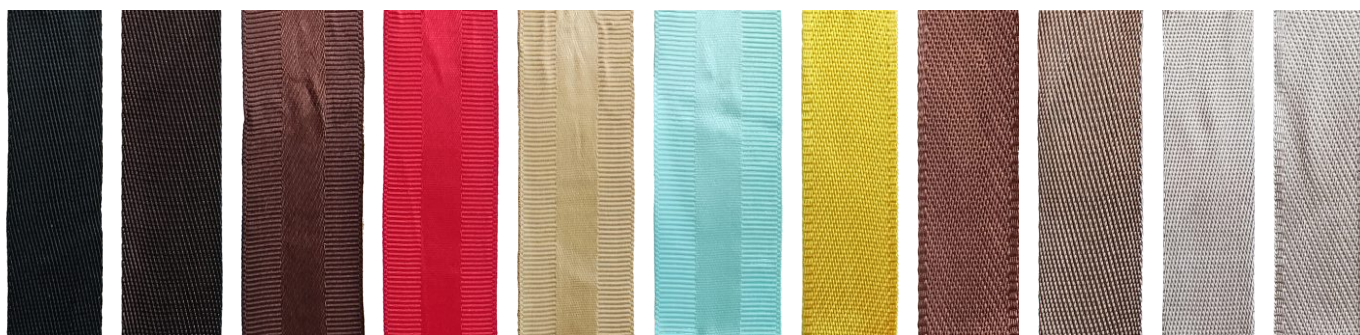
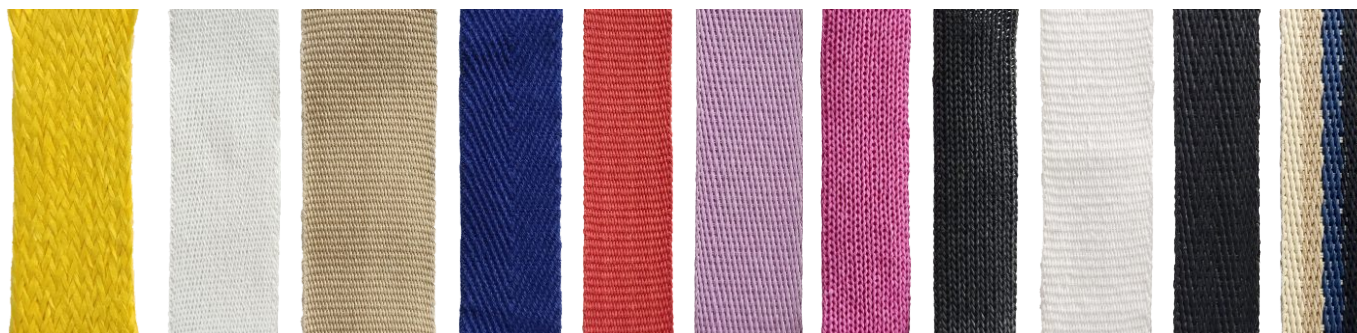



支持各种袋底样式 Support Various Bag Bottom Styles



颠覆传统，助力更多优势 Disrupting Tradition Fueling More Advantage



智能参数输入系统

“核心参数一键设定”:袋高/袋宽/孔距/打孔高度/绳长/鸭舌扣长度等数据,通过10.1寸工业级触控屏直接输入,系统自动计算最优路径,告别传统机械反复调试,换型效率提升90%。

Intelligent Parameter Input System

“Core parameters set by one key”: bag height/bagwidth/hole spacing/perforation height/rope length/ducktongue buckle length and other data, through the 10.1-inch industrial-grade touch screen directly input, the system automatically calculates the optimal path, goodbye to the traditional mechanical repeated debugging, the efficiency of the changeover increased by 90%.

工艺数据库(记忆存储功能)

历史生产数据(袋型参数、穿绳长度)自动存档,支持命名快速调用,相同订单再次生产时‘秒级启动’,杜绝人为操作误差。

Process Database(memory Storage function)

Historical production data (bag parameters, stringing length) are automatically archived, support for naming and quick recall, and 'start in seconds' when the same order is produced again, eliminating human error in operation.



传统设备升级对比 Comparison Of conventional Equipment Upgrades

Function 功能	Conventional stringing machines 传统穿绳机	Intelligent Rope Threading Machine 智能穿绳机
Parameter setting method 参数设置方式	Manual adjustment of mechanical parts+ trial and error 手动调节机械部件+试错	Panel digital input +auto calibration 面板数字输入+自动校准
Historical process reuse 历史工艺复用	Historical process reuse 历史工艺复用	Database one-key call 数据库一键调用
Multi-specification compatibility 多规格兼容性	Multi-specification compatibility 多规格兼容性	Support bag width 150-550mm, rope length 270-580mm 支持袋宽150-540mm、绳长270-580mm

VS

客户每日10小时生产需切换5种袋型，传统设备调试耗时占生产时长40%：**启用智能穿绳机后，通过参数预存功能**

The customer needs to switch 5 types of bags for 10 hours of production per day, and the debugging time of traditional equipment accounts for 40% of the production time; After Intelligent Stringing Machine is enabled, through the parameter pre-storage function,

4 ⌘

Increased net production time
by 4 hours per day
每日净生产时间**增加4小时**

通过将复杂的机械调试转化为“输入数字→自动执行”的极简操作并赋予数据存储与复用的管理价值，可直观传达“智能=降本+增效+零门槛”的核心竞争力。

50,000 💰

Annual labor cost
savings of over 50,000 RMB
年节省人力成本**超5万元**

By transforming complex mechanical commissioning into the minimalist operation of "inputting numbers-automatic execution and giving data storage and reuse management value, the core competitiveness of "Intelligence = Cost Reduction, Efficiency Increase, Zero Threshold" can be conveyed intuitively. "Intelligence= Cost Reduction + Efficiency + Zero Threshold" is the core competitiveness.

3,000,000 ¥

Increase annual production capacity by
more than 3 million dollars per machine
每台机年增产能**超300万**



主要技术参数 TechnicalData

纸袋尺寸 Sheet Paper Size		
袋面最小尺寸	Min. bag Size	150x160x(80-100)mm
袋面最大尺寸	Max. bag Size	540x450x(80-250)mm
纸张克重 Bag tickness		
纸张克重	Bag tickness	140-300GSM
孔位 Hole position		
穿绳孔位间距	Drawsring hole spacing	65-200mm
孔位内径	Hole diameter	4-6mm
运行 Running		
带鸡眼速度	Speed include pumping eyes	50pcs/min
不带鸡眼速度	Speed without pumping eyes	50pcs/min
安装要求 Installation		
功率	Power	8.2kw
尺寸和重量 Dimensions and weight		
设备尺寸	Size	3400x2000x2200mm
重量	Weight	2.2T
绳长String length		
绳长	String length	Min.200mm plus hole spacing Total length 270-580mm, excluding rope tension (最短200mm+孔距)总长度270-580mm(含绳子张力)
绳长String length		
吊牌适用范围	Hanging Tag Application Range	40mm -140mm



核心配件 Core Accessories

Item Name	Brand	Origin
servo motor	DELTA	Taiwan
Controller	DELTA	Taiwan
Control screen	Kunlun	China
Stepper driver	Yankong	Taiwan
Relay head	Honeywell	USA
Relay base	Honeywell	USA
Short piece	Weidmiller	Germany
Switching Mode Power	MingWei	Taiwan
photoelectricity	Omron	China
Cylinder	Airtac	Taiwan
Bearing	NSK/HRB	Japan/China
Synchronous belt	Jagua	China



设备占地规划 Machine Floor Plan

