

Beli Chan

Sales Manager

M: +86 139 2586 8276

WhatsApp: +86 139 2586 8276

E-mail: Beli@championbagmaker.com

MACHINERY MANUFACTURER OF LUXURY PAPER BAGS

CHAMPION MACHINERY MANUFACTURING CO.,LTD.

Add: 42#2and Longyan Industrial Avenue, Humen Town Dongguan City, China PR
Website: www.paper-bag-machine.com

CHAMPION
MACHINERY



Coffee Gong

Sales

M: +86 186 8118 5198

WhatsApp: +86 134 2327 5528

E-mail: sales8@championbagmaker.com

MACHINERY MANUFACTURER OF LUXURY PAPER BAGS

CHAMPION MACHINERY MANUFACTURING CO.,LTD.

Add: 42#2and Longyan Industrial Avenue, Humen Town Dongguan City, China PR
Website: www.paper-bag-machine.com

CHAMPION
MACHINERY

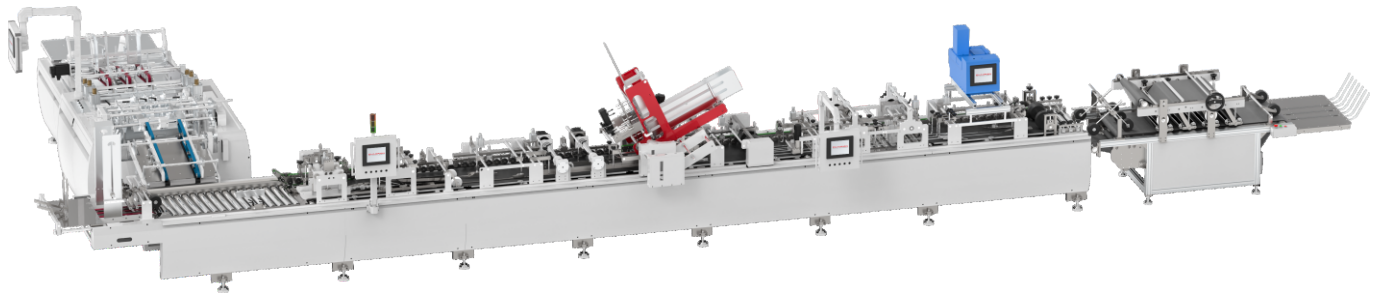

CMBF-420A/520A/600A + CMBS-1000RS

Paper Bag Bottom Folding + Gluing Machine With
Auto Bottom Cardboard Pasting In Line

纸袋拉底+自动底卡糊底机

目录

Contents

机器名称图片 Machine Name Image	3
工艺流程图 Process Flowchart	3
机器说明 Machine Description	4
机器特点 Machine Features	4
参数示意图 Sheet Paper Data	4
主要技术参数 Technical Data	5
设备占地规划 Machine Floor Plan	5
核心配件 Core Accessories	6

CMBF-420/520A/600A + CMBS-1000RS

Paper Bag Bottom Folding + Gluing Machine
With Auto Bottom Cardboard Pasting In Line
纸袋拉底+自动底卡糊底机

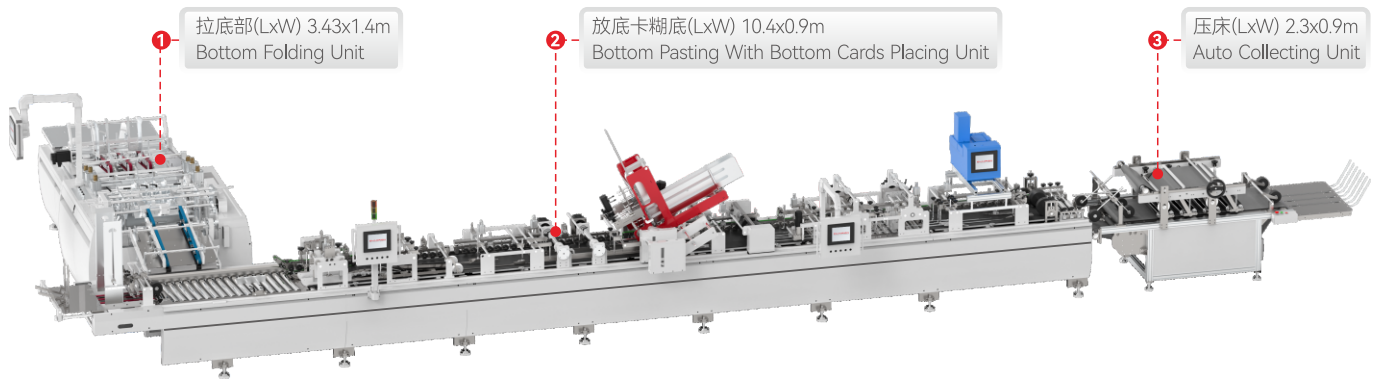

工艺流程图 Process Flowchart

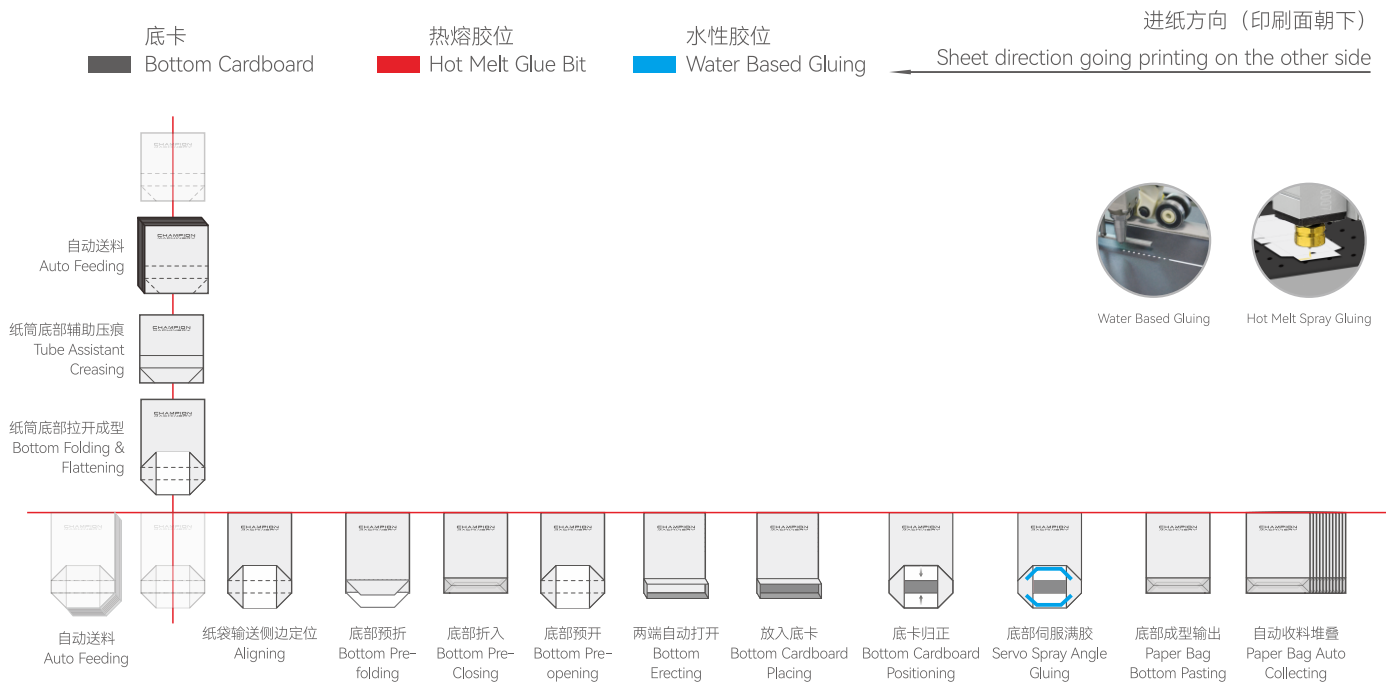



机器说明 Machine Description

该设备采用半自动模组线纸袋拉底+自动底卡糊底机，是一款集灵活、高效与高度自动化于一体的纸袋生产设备，专为满足单张纸袋各种拉底、糊底需求而设计。该设备凭借其广泛的应用领域，如服装、礼品及购物纸袋等，展现了强大的市场适应性。

This equipment utilizes a semi-automatic modular line for paper bag bottom drawing and an automatic bottom Cardboard gluing machine. It combines flexibility, efficiency, and a high degree of automation in paper bag production, specifically designed to meet various bottom drawing and gluing requirements for single-sheet paper bags. This equipment demonstrates strong market adaptability with its wide range of applications, including clothing, giftware, and shopping paper bags.



机器特点 Machine Features

1. 该机器不仅可以生产不同尺寸和结构的纸袋，节省大量劳动力，还能精确控制纸袋生产，效率高，合格率高。
2. 更广泛的进料尺寸范围，主要功能：拉底+自动放底卡+自动糊底，让您有机会战胜手工作业或竞争对手的机器。
3. 机器功能设计为独立模块，可根据纸袋工艺要求自由装配模块（自动放入底卡）。
4. 该生产线生产的纸袋工艺堪比手工作业，甚至更胜一筹。同时，制袋效率、精度和产量显著提高，成本、交货时间和管理成本也大幅降低。
5. 设计并配备防卡纸系统，防止生产过程中发生卡纸或持续卡纸。

1. This machine can not only produce paper bags of various sizes and structures, saving a significant amount of labor, but it also allows for precise control over the bag-making process, resulting in high efficiency and an excellent pass rate.
2. With a wider range of feeding size capabilities, its main functions include bottom forming, automatic bottom card inserting, and automatic bottom gluing — giving you a competitive edge over manual operations or rival machines.
3. The machine is designed with independent modular components, allowing for flexible assembly based on specific paper bag requirements (such as automatic bottom card insertion).
4. The paper bags produced by this production line rival, and even surpass, those made by hand in terms of craftsmanship. At the same time, bag-making efficiency, precision, and output are significantly improved, while costs, delivery times, and management overhead are greatly reduced.
5. It is designed with a paper-jam prevention system to avoid single or continuous paper jams during the production process.



参数示意图 Sheet Paper Data

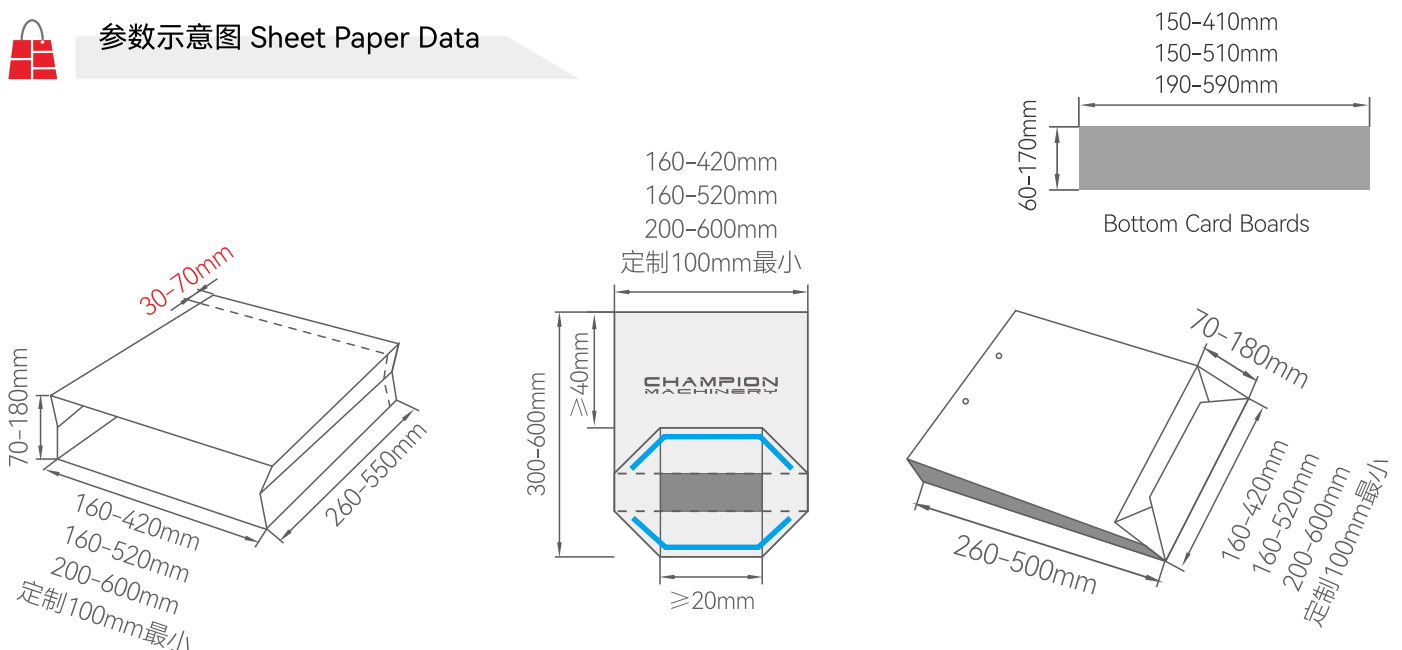



主要技术参数 TechnicalData

纸筒尺寸 Paper Bag Tube Size		
纸筒宽度	Paper Bag Tube Width	160-420mm/420A 160-520mm/520A 200-600mm/600A
纸筒长度	Paper Bag Tube Length	260-550mm
风琴尺寸	Paper Bag Gusset	70-180mm
适用纸张原材料和耗材 Suitable Paper Material & Glue & Handle		
牛皮纸	Kraft Paper	120-350gsm
铜版纸/覆膜纸	Coat Paper / Laminated	128-250gsm
白卡纸	White Board Paper	157-300gsm
灰板纸	Grey Board Paper	128-300gsm
胶水	Glue	标配热熔胶, 选配水性冷胶 Hot melt glue option water base glue
手提绳	Handle	纸手腕圆/扁, 贴丝带, 打头手提绳子/丝带 其他 Flat paper handle, twisted paper handle, tipping with rope or ribbon handle, Ribbon handles with top cardboard pasting glue fix of luxury paper bag
底卡 Bottom Cardboards		自动 Auto
底卡宽度	Bottom Cardboards Width	60-170mm
底卡长度	Bottom Cardboards Length	140-410mm(420A) 140-500mm(520A) 180-580mm(600A)
底卡克重	Bottom Cardboards Thickness	200-500gsm
运行 Running		
速度	Speed	0-70 pcs/min
安装要求 Installation		
装机总功率	Total Power Supply	27.5KW
压缩空气	Compressed Air / Capacity	6bar
储气罐能量	Air Tank Capacity	15m ³ /h



设备占地规划 Machine Floor Plan

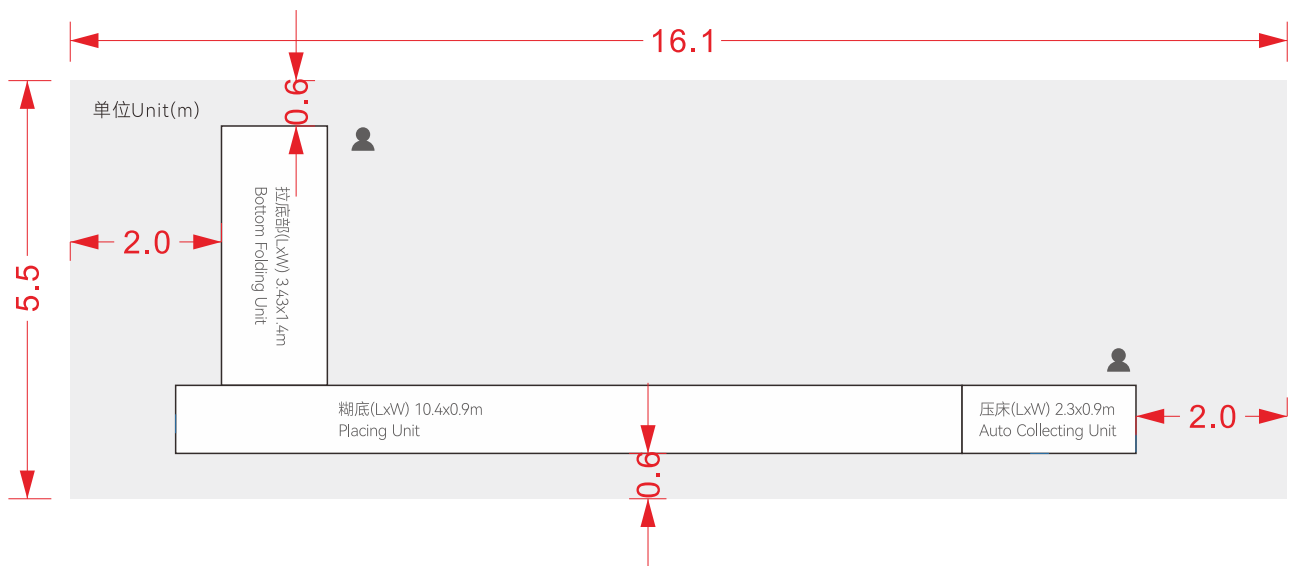



核心配件 Core Accessories



SynMatic

运动控制系统
伺服电机/伺服驱动/变频器
SIMOTION
Servo motor/servo drive/frequency converter

安驰 中国
SynMatic China



KEYENCE

总线控制
BUS CONTROL

基恩士 日本
Keyence Nippon



Honeywell

编码器/接近开关
热过载继电器接触器
ENCODER/PROXIMITY SWITCH
Thermal overload relay contactor

霍尼韦尔 美国
Honeywell US



KEYENCE

主光电眼/光纤
MAIN OPTICAL EYE/FIBER

基恩士 日本
Keyence Nippon



触摸屏
TOUCH SCREEN

威伦 台湾
WEINVIEW Taiwan



MAC

电磁阀
SOLENOID VALVE

MAC 美国
MAC US



CPG

减速机马达
REDUCER MOTOR

晟邦 台湾
Shengbang CPG Taiwan



SIEMENS

主马达
MAIN MOTOR

西门子贝德 德国
Siemens Bader Germany



ORION

真空泵
VACUUM PUMP

好利旺 日本
ORION Japan