

Beli Chan

Sales Manager

M: +86 139 2586 8276

WhatsApp: +86 139 2586 8276

E-mail: Beli@championbagmaker.com

MACHINERY MANUFACTURER OF LUXURY PAPER BAGS

CHAMPION MACHINERY MANUFACTURING CO.,LTD.

Add: 42#2nd Longyan Industrial Avenue, Humen Town Dongguan City, China PR
Website: www.paper-bag-machine.com

CHAMPION
MACHINERY



Coffee Gong

Sales

M: +86 186 8118 5198

WhatsApp: +86 134 2327 5528

E-mail: sales8@championbagmaker.com

MACHINERY MANUFACTURER OF LUXURY PAPER BAGS

CHAMPION MACHINERY MANUFACTURING CO.,LTD.

Add: 42#2nd Longyan Industrial Avenue, Humen Town Dongguan City, China PR
Website: www.paper-bag-machine.com

CHAMPION
MACHINERY

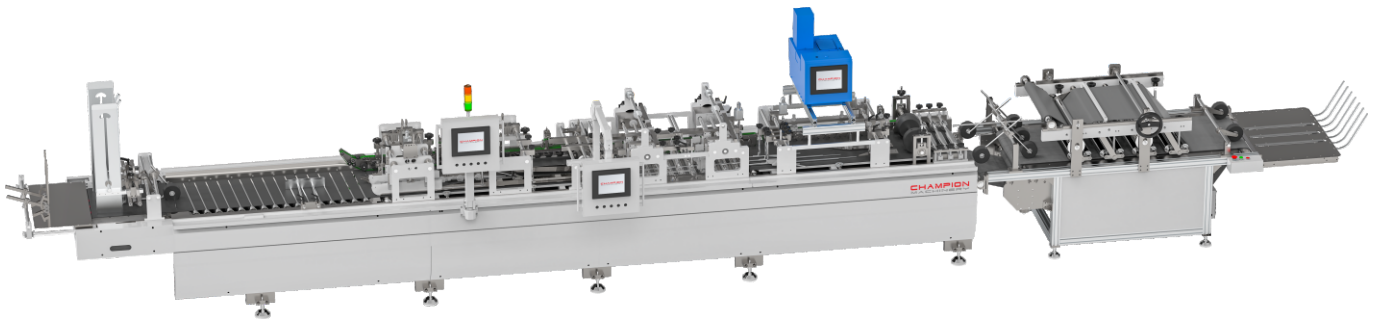

CMBS-600AC

Paper Bag Bottom Gluing Machine

纸袋糊底机升级版

目录

Contents

机器名称图片 Machine Name Image	3
工艺流程图 Process Flowchart	3
机器说明 Machine Description	4
机器特点 Machine Features	4
参数示意图 Sheet Paper Data	4
主要技术参数 Technical Data	5
设备占地规划 Machine Floor Plan	5
核心配件 Core Accessories	6

CMBS-600AC

Paper Bag Bottom Gluing Machine

纸袋糊底机升级版

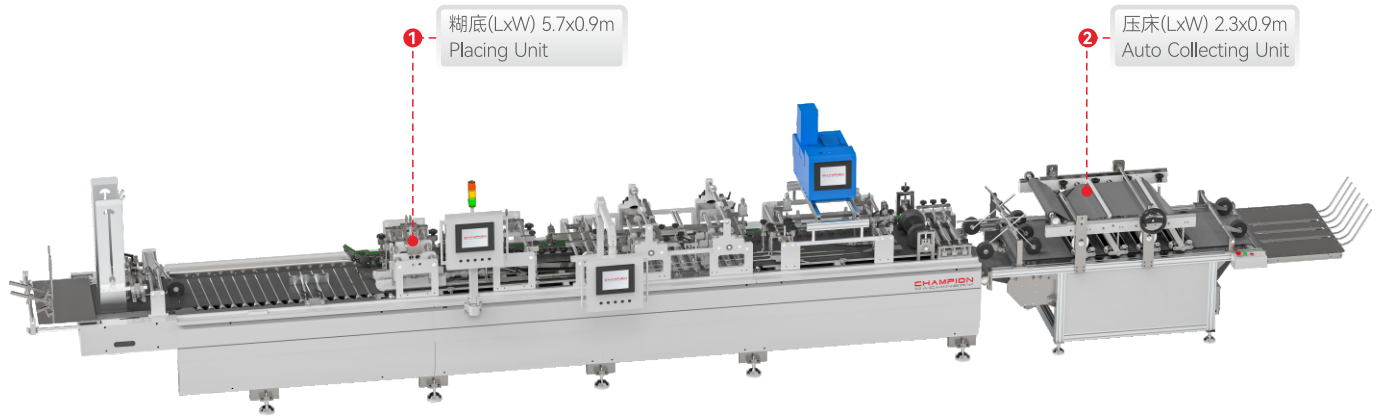

工艺流程图 Process Flowchart

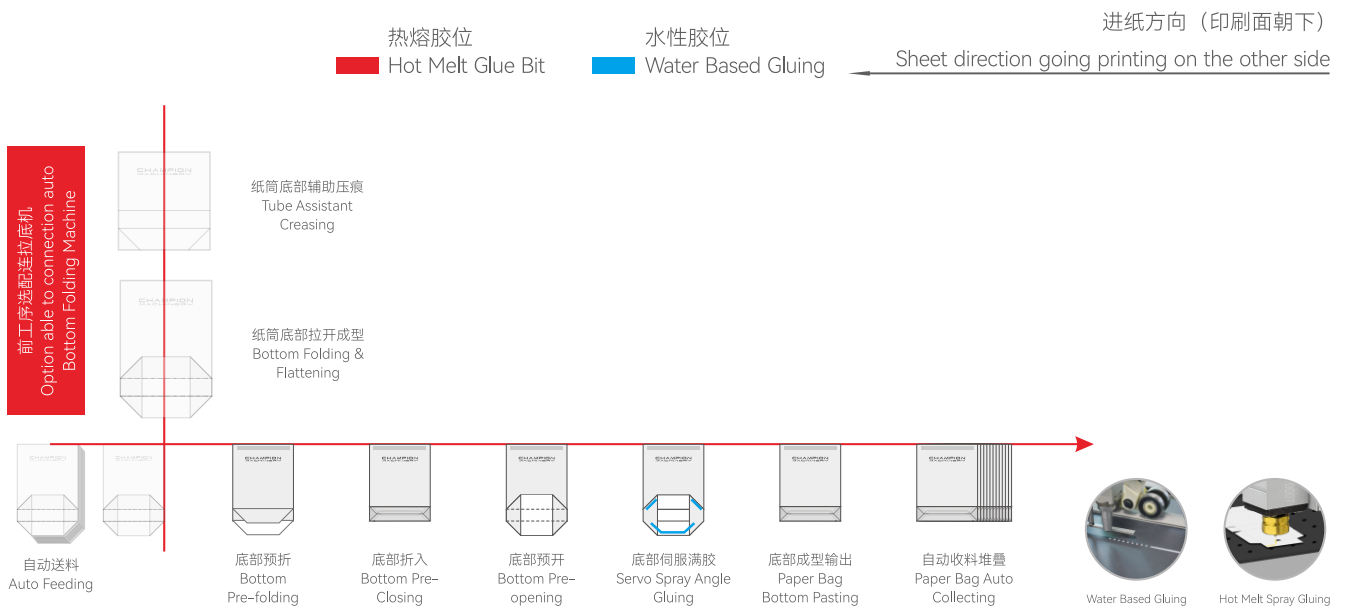



机器说明 Machine Description

糊底机是一种专业用于纸袋底部成型与粘合的自动化设备，通过精准控制粘合剂涂抹、袋底拉伸定位和热压固化流程，实现纸袋底部密封成型。主要应用于服装包装、食品包装、购物手提袋等领域的生产。

通过采用高速、高精度生产工艺以及智能化控制系统，实现降低成本、提升效率和优化质量。其模块化设计理念使得设备能够灵活应对不同生产需求，同时环保特性也符合当前绿色生产的趋势，成为传统纸袋生产设备升级换代的首选方案。

The bottom gluing machine is an automated device specialized for forming and gluing paper bag bottoms. It achieves a sealed bottom by precisely controlling the adhesive application, bottom stretching and positioning, and heat-pressing curing processes. It is primarily used in the production of clothing packaging, food packaging, shopping bags, and other fields.

By utilizing high-speed, high-precision production processes and intelligent control systems, it reduces costs, improves efficiency, and optimizes quality. Its modular design allows for flexible adaptation to diverse production needs. Its environmentally friendly features align with current trends in green production, making it a leading upgrade option for traditional paper bag production equipment.



机器特点 Machine Features

高效自动化生产：连续式工作模式，集成送袋、喷胶、压合全流程，显著提升效率，减少人工依赖；触摸屏控制+PLC编程系统，实现参数一键调节。

精准控制与稳定性：光纤传感器实时监控胶量及位置，误差 $\leq \pm 200g/816$ 。

灵活适配多场景：可通过更换模具适配不同袋型（如方底、尖底、阀口袋）。

支持多种材质：牛皮纸、覆膜纸、纸纱复合袋等等。

环保与低耗设计：采用可降解热熔胶，减少污染；节能部件（如变频电机）降低能耗，比传统手工糊底胶耗下降30%。

智能维护与耐用性：模块化结构便于关键部件更换，自检系统实时预警电气故障（如马达过热、胶路堵塞）。

Efficient Automated Production: Continuous working mode integrates the entire process of bag feeding, glue spraying, and pressing, significantly improving efficiency and reducing manual dependence; touch screen control + PLC programming system enables one-click parameter adjustment.

Precise Control and Stability: Fiber optic sensors monitor glue volume and position in real time, with an accuracy of $\leq \pm 200g$.

Flexible Adaptability: Exchanging molds allows for adaption to various bag shapes (such as square bottoms, pointed bottoms, and valve bags).

Supports a variety of materials: kraft paper, coated paper, paper-yarn composite bags, and more.

Environmentally friendly and low-energy design: Biodegradable hot-melt adhesive reduces pollution; energy-saving components (such as a variable-frequency motor) reduce energy consumption, reducing glue consumption by 30% compared to traditional manual primer application.

Smart maintenance and durability: The modular structure facilitates replacement of key components, and the self-diagnosis system provides real-time warning of electrical faults (such as motor overheating and glue line blockage).



参数示意图 Sheet Paper Data

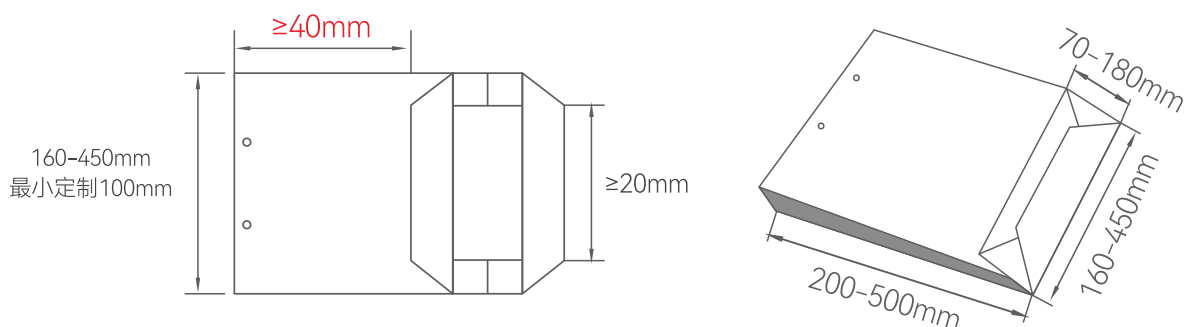



主要技术参数 TechnicalData

纸筒尺寸 Paper Bag Tube Size		
纸筒宽度	Paper Bag Tube Width	160-450mm Customized Min 100mm
纸筒长度	Paper Bag Tube Length	200-500mm
风琴尺寸	Paper Bag Gusset	70-180mm
适用纸张原材料和耗材 Suitable Paper Material & Glue & Handle		
牛皮纸	Kraft Paper	120-350gsm
铜版纸/覆膜纸	Coat Paper / Laminated	128-250gsm
白卡纸	White Board Paper	157-300gsm
灰板纸	Grey Board Paper	128-300gsm
胶水	Glue	标配热熔胶, 选配水性冷胶 Hot melt glue option water base glue
手提绳	Handle	纸手腕圆/扁, 贴丝带, 打头手提绳子/丝带 其他 Flat paper handle, twisted paper handle, tipping with rope or ribbon handle, Ribbon handles with top cardboard pasting glue fix of luxury paper bag
运行 Running		
速度	Speed	0-80 pcs/min
电压	Voltage	380V/220V 50/60HZ 3 phase
生产功率	Production Power	5-6KW
安装要求 Installation		
装机总功率	Total Power Supply	14.5KW
压缩空气	Compressed Air / Capacity	6bar
储气罐能量	Air Tank Capacity	15m ³ /h



设备占地规划 Machine Floor Plan

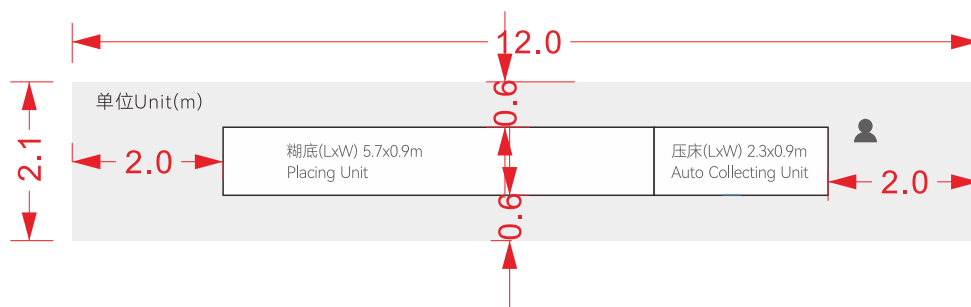



核心配件 Core Accessories



SynMatic

运动控制系统
伺服电机/伺服驱动/变频器
SIMOTION
Servo motor/servo drive/frequency converter

安驰 中国
SynMatic China



KEYENCE

总线控制
BUS CONTROL

基恩士 日本
Keyence Nippon



Honeywell

编码器/接近开关
热过载继电器接触器
ENCODER/PROXIMITY SWITCH
Thermal overload relay contactor

霍尼韦尔 美国
Honeywell US



KEYENCE

主光电眼/光纤
MAIN OPTICAL EYE/FIBER

基恩士 日本
Keyence Nippon



触摸屏
TOUCH SCREEN

威伦 台湾
WEINVIEW Taiwan



电磁阀
SOLENOID VALVE

MAC 美国
MAC US



CPG

减速机马达
REDUCER MOTOR

晟邦 台湾
Shengbang CPG Taiwan



SIEMENS

主马达
MAIN MOTOR

西门子贝德 德国
Siemens Bader Germany



ORION

真空泵
VACUUM PUMP

好利旺 日本
ORION Japan