

## Beli Chan

Sales Manager

M: +86 139 2586 8276

WhatsApp: +86 139 2586 8276

E-mail: Beli@championbagmaker.com

MACHINERY MANUFACTURER OF LUXURY PAPER BAGS

CHAMPION MACHINERY MANUFACTURING CO.,LTD.

Add: 42#2and Longyan Industrial Avenue, Humen Town Dongguan City, China PR  
Website: www.paper-bag-machine.com

**CHAMPION**  
MACHINERY



## Coffee Gong

Sales

M: +86 186 8118 5198

WhatsApp: +86 134 2327 5528

E-mail: sales8@championbagmaker.com

MACHINERY MANUFACTURER OF LUXURY PAPER BAGS

CHAMPION MACHINERY MANUFACTURING CO.,LTD.

Add: 42#2and Longyan Industrial Avenue, Humen Town Dongguan City, China PR  
Website: www.paper-bag-machine.com

**CHAMPION**  
MACHINERY

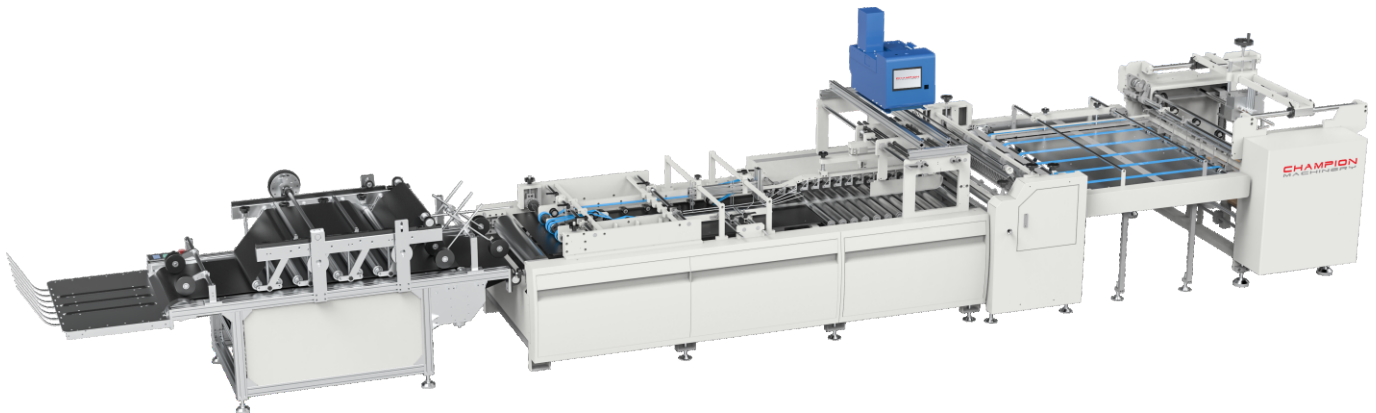

## CMTF-1100

Paper Bag Tube Forming (Hot Selling)

纸袋糊筒机 (畅销款)

## 目录

### Contents

机器名称图片 Machine Name Image	3
工艺流程图 Process Flowchart	3
机器说明 Machine Description	4
机器特点 Machine Features	4
参数示意图 Sheet Paper Data	4
主要技术参数 Technical Data	5
设备占地规划 Machine Floor Plan	5
核心配件 Core Accessories	6

# CMTF-1100

Paper Bag Tube Forming (Hot Selling)

纸袋糊筒机 (畅销款)

Economy Flexibility High Efficiency

经济 灵活 高效

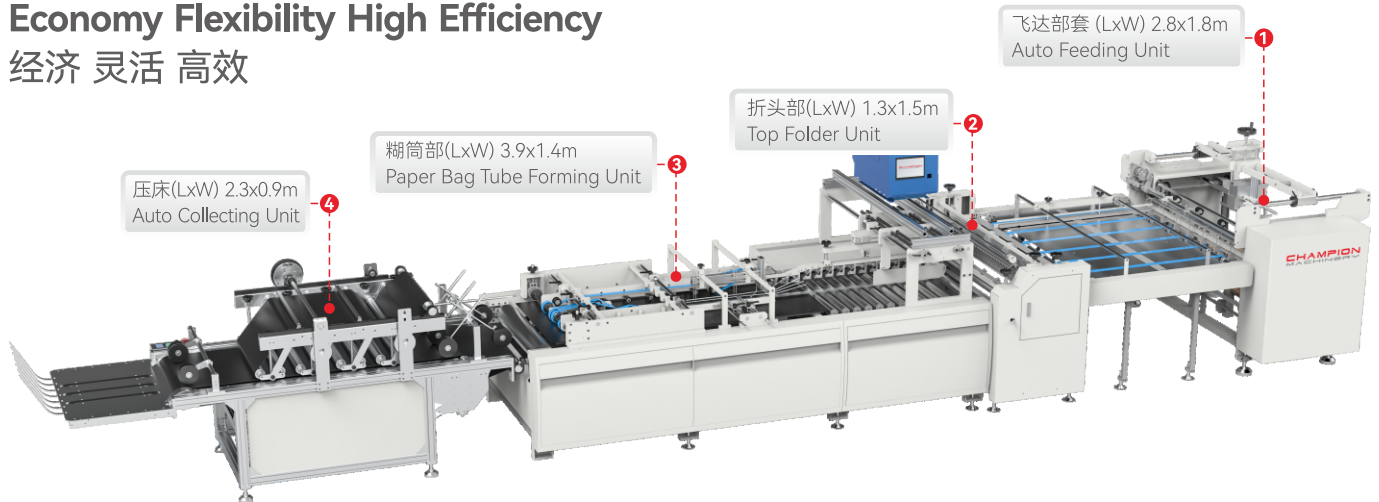

**2000+**

最小上机数量  
MOQ Sheets

**30-45**  
mins

调机时间  
Size Change

**5000+**  
hour

每小时的产量  
Capacity / Hour

**0.03%**

报损率  
Wastage Rate

**0**

零经验  
0 Skills

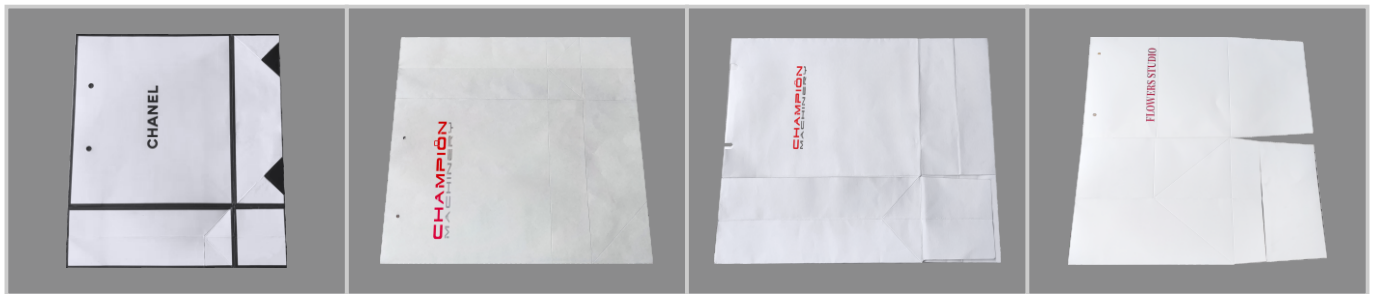

## 工艺流程图 Process Flowchart

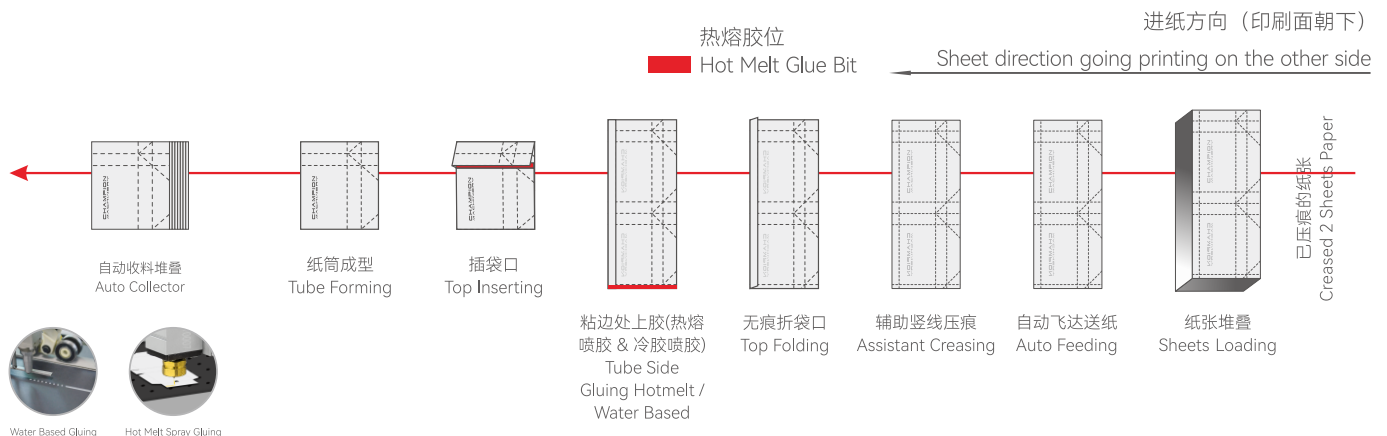



## 机器说明 Machine Description

纸袋糊筒机是纸袋生产中的核心设备，用于将单张压痕纸板自动粘合成筒状结构，为后续糊底工序提供预制筒体。其工作流程主要包括自动送纸、定位校准、上胶糊筒、风琴位折叠及压合成型等环节。

主要应用于服装袋、购物袋、礼品袋、食品包装袋等纸容器的筒体制作，适配牛皮纸、铜版纸、覆膜纸等多种材质。

The paper bag tube gluing machine is a core piece of equipment in paper bag production. It automatically glues single sheets of creased cardboard into a tube-shaped structure, providing a prefabricated tube for the subsequent gluing process. Its workflow primarily includes automatic paper feeding, positioning and calibration, gluing and gluing, accordion folding, and pressing and forming.

It is primarily used to produce tubes for paper containers such as garment bags, shopping bags, gift bags, and food packaging bags. It is compatible with a variety of materials, including kraft paper, coated paper, and laminated paper.



## 机器特点 Machine Features

**高效连续生产:** 全自动送纸系统配合变频调速，实现每分钟70-100个纸筒的高速输出。集成糊筒、折风琴、压合流水线，减少人工干预。

**精准定位控制:** 光电传感器+侧规/拉规系统，确保纸张对位精度 $\leq \pm 0.5\text{mm}$ ，伺服电机驱动配合PLC编程，实现风琴位折叠深度、压合力度等参数一键调节。

**灵活适配多场景:** 适用克重范围广（150-350g），包括覆膜纸、纸纱复合等特殊材质。

**智能胶控系统:** 可选冷胶滚涂或热熔胶喷胶技术，胶量独立调控避免溢胶，部分机型配备胶路自检功能，实时预警堵塞故障。

**耐用易维护设计:** 关键部件采用耐磨材料，延长使用寿命。

**Efficient and Continuous Production:** A fully automatic paper feeding system with variable frequency speed control achieves a high-speed output of 70-100 paper tubes per minute. Integrated tube gluing, accordion folding, and laminating lines reduce manual intervention.

**Precise Positioning Control:** A photoelectric sensor plus side/pull gauge system ensures paper alignment accuracy  $\leq \pm 0.5\text{mm}$ . A servo motor drive coupled with PLC programming allows one-touch adjustment of parameters such as accordion fold depth and laminating force.

**Flexible Adaptability:** Suitable for a wide range of weights (150-350g), including special materials such as coated paper and paper-yarn composites.

**Intelligent Glue Control System:** Available with either cold glue roller coating or hot melt glue spraying technology, glue quantity is independently controlled to prevent overflow. Select models feature a glue path self-diagnosis function, providing real-time warning of blockages and faults.

**Durable and Maintenance-Friendly Design:** Key components are constructed of wear-resistant materials for extended service life.



## 参数示意图 Sheet Paper Data

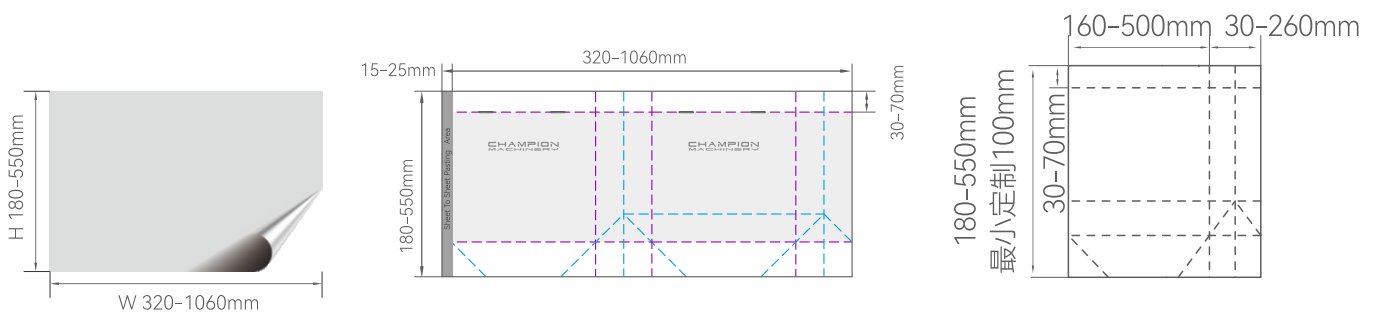



## 主要技术参数 TechnicalData

单张纸张尺寸 Sheet Paper Size		
W进纸宽度范围	Sheet Paper Width	320-1060mm
H进纸长度范围	Sheet Paper Length	180-550mm
纸筒尺寸 Paper Bag Tube Size		
折袋口尺寸	Paper Bag Top Folder Depth	30-70mm
纸筒宽度	Paper Bag Tube Width	160-500mm Customized Min 100mm
纸筒长度	Paper Bag Tube Length	180-550mm
风琴尺寸	Paper Bag Gusset	30-260mm
粘位尺寸	Sheet Paper Glue Side	15-25mm
适用纸张原材料和耗材 Suitable Paper Material & Glue & Handle		
牛皮纸	Kraft Paper	120-350gsm
铜版纸/覆膜纸	Coat Paper / Laminated	128-250gsm
白卡纸	White Board Paper	157-300gsm
灰板纸	Grey Board Paper	128-300gsm
胶水	Glue	标配热熔胶, 选配水溶性冷胶 Hot melt glue option water base glue
手提绳	Handle	纸手腕圆/扁, 贴丝带, 打头手提绳子/丝带 其他 Flat paper handle, twisted paper handle, tipping with rope or ribbon handle, Ribbon handles with top cardboard pasting glue fix of luxury paper bag
运行 Running		
速度	Speed	0-100 pcs/min
电压	Voltage	380V/220V 50/60HZ 3 phase
生产功率	Production Power	5-6KW
机器尺寸和重量 Machine Size & Weight		
机器	Size	10×1.8×1.6M
重量	Weight	1400kg
安装要求 Installation		
装机总功率	Total Power Supply	16.5KW
压缩空气	Compressed Air / Capacity	6bar
储气罐能量	Air Tank Capacity	15m³/h



## 设备占地规划 Machine Floor Plan

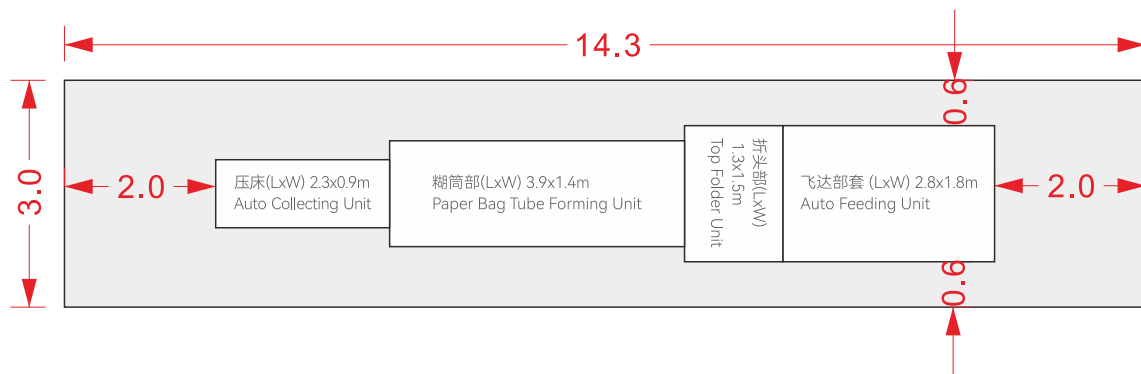



核心配件 Core Accessories



**SynMatic**

运动控制系统  
伺服电机/伺服驱动/变频器  
SIMOTION  
Servo motor/servo drive/frequency converter

安驰 中国  
SynMatic China



**KEYENCE**

总线控制  
BUS CONTROL

基恩士 日本  
Keyence Nippon



**Honeywell**

编码器/接近开关  
热过载继电器接触器  
ENCODER/PROXIMITY SWITCH  
Thermal overload relay contactor

霍尼韦尔 美国  
Honeywell US



**KEYENCE**

主光电眼/光纤  
MAIN OPTICAL EYE/FIBER

基恩士 日本  
Keyence Nippon



触摸屏  
TOUCH SCREEN

威伦 台湾  
WEINVIEW Taiwan



**MAC**

电磁阀  
SOLENOID VALVE

MAC 美国  
MAC US



**CPG**

减速机马达  
REDUCER MOTOR

晟邦 台湾  
Shengbang CPG Taiwan



**SIEMENS**

主马达  
MAIN MOTOR

西门子贝德 德国  
Siemens Bader Germany



**ORION**

真空泵  
VACUUM PUMP

好利旺 日本  
ORION Japan