

A0
Version

CHAMPION
MACHINERY

MACHINERY MANUFACTURER OF **LUXURY PAPER BAGS**
CHAMPION MACHINERY MANUFACTURING CO.,LTD.



Tel: +86 139 2586 8276
WhatsApp: +86 139 2586 8276



E-mail: Bel@championbagmaker.com
Website: www.paper-bag-machine.com



Add: 42#2and Longyan Industrial Avenue, Humen Town
Dongguan City, China PR

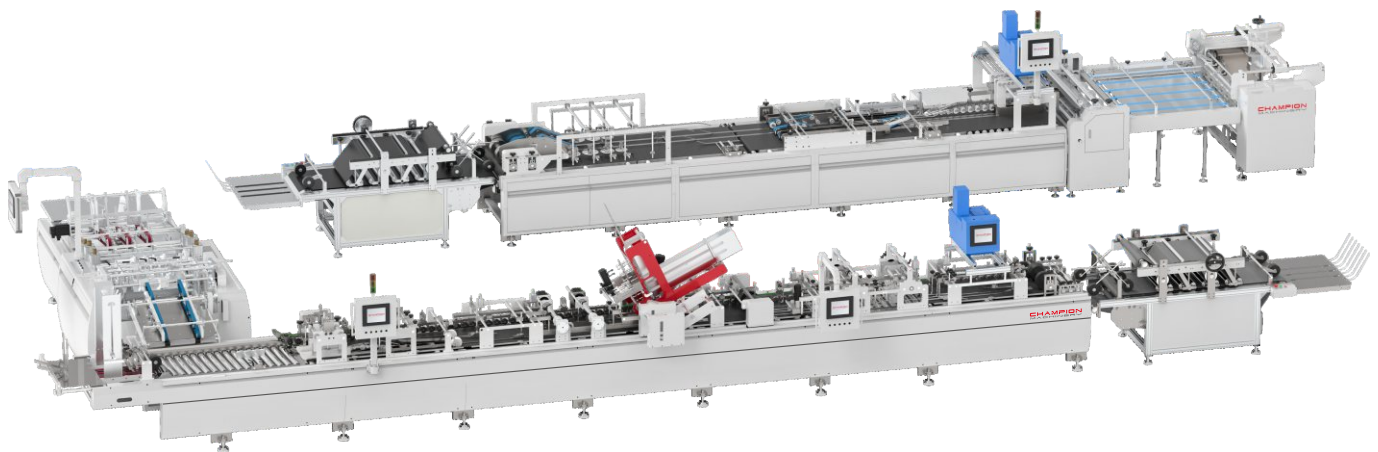

CMTF-1100AT + CMBF-420A + CMBS-1000RS

Sheet Fed Paper Bag Production Line GROUP A + B

单张纸袋生产线

目录

Contents

机器名称图片 Machine Name Image	3
工艺流程图 Process Flowchart	3
机器说明 Machine Description	4
机器特点 Machine Features	4
参数示意图 Sheet Paper Data	5
主要技术参数 Technical Data	6
设备占地规划 Machine Floor Plan	6
核心配件 Core Accessories	7

CMTF-1100AT CMBF-420A /520A + CMBS-1000RS

Sheet Fed Paper Bag Production Line
With Auto Bottom Cards Pasting A + B

单张纸袋生产线组合 (带自动底卡A+B)

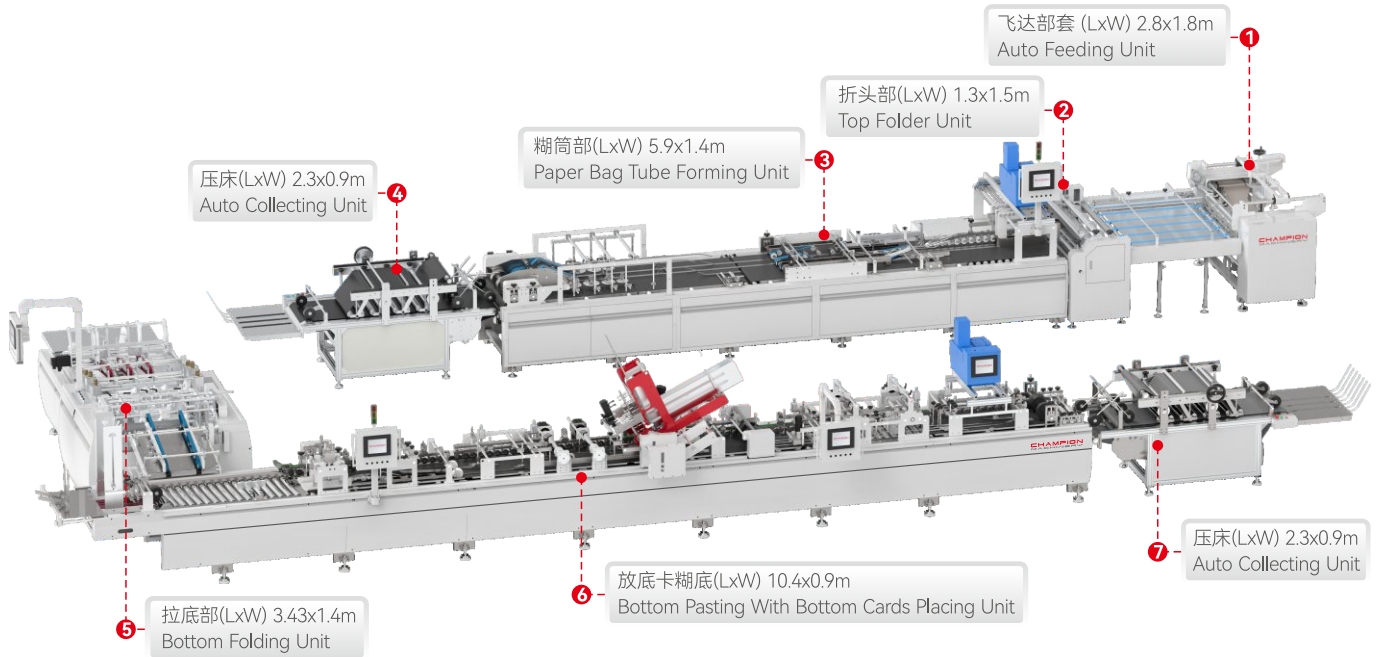

工艺流程图 Process Flowchart

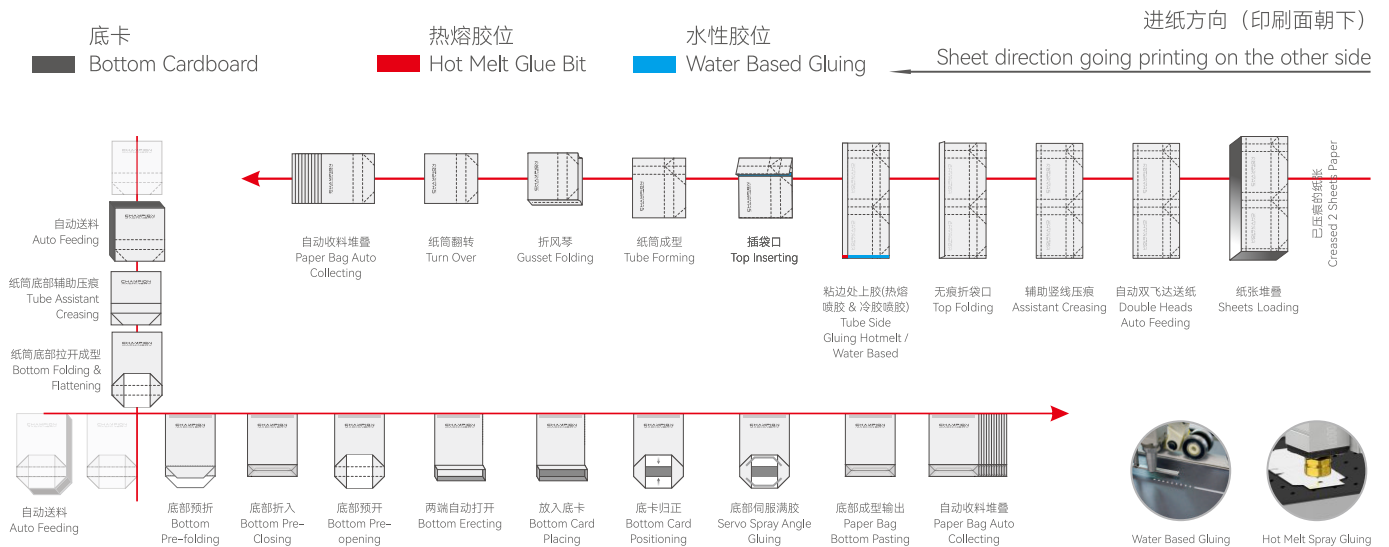



机器说明 Machine Description

该设备采用A+B两条半自动模组线组合的自动单张纸袋机，是一款集灵活、高效与高度自动化于一体的纸袋生产设备，专为满足单张纸袋各种工艺生产需求而设计。该设备凭借其广泛的应用领域，如服装、礼品及购物纸袋等，展现了强大的市场适应性。

通过采用高速、高精度生产工艺以及智能化控制系统，实现降低成本、提升效率和优化质量。其模块化设计理念使得设备能够灵活应对不同生产需求，同时环保特性也符合当前绿色生产的趋势，成为传统纸袋生产设备升级换代的首选方案。

This automatic sheet-fed paper bag machine, combining two semi-automatic modular lines (A+B), combines flexibility, efficiency, and a high degree of automation. Designed to meet the diverse production requirements of sheet-fed paper bags, this equipment demonstrates strong market adaptability with its wide range of applications, including clothing, gift ware, and shopping paper bags.

By employing high-speed, high-precision production processes and an intelligent control system, it reduces costs, improves efficiency, and optimizes quality. Its modular design allows for flexible adaptation to diverse production needs. Its environmentally friendly features align with current trends in green production, making it a leading upgrade option for traditional paper bag production equipment.



机器特点 Machine Features

1. 高级单张送纸流水线及输送设计，稳定高效，产能灵活。
 2. 适用于多种厚度和尺寸的纸张，省时高效，调试简单，性能稳定，价格实惠，性价比高。
 3. 单张送纸及输送部分采用电脑伺服技术，可与后成型部分精确同步速度，并可实现对前成型部分的单独控制。
 4. 维护简单，使用寿命长，无缺陷折盖、插盖，产量高，制袋均匀，深受客户好评。
 5. 该机器在节省大量劳动力的同时，大大提高了生产效率。广泛应用于不同规模或业务类型的印刷包装企业。
 6. 配备遥控器，操作简便，易于上手，易于操作，甚至可实现无人值守。
1. High-level streamlined sheet paper feeding and conveying design, stable and efficient, with flexible production capacity
 2. Applicable to a variety of thicknesses and dimensions of paper, saving time and efficiency, with simple commissioning and stable performance, and affordable and cost-effective performance
 3. Computerized Servo technology is used for the sheet paper feeding and conveying sections, which can synchronize with the precise speed of the rear forming section and can achieve separate control over the former section.
 4. Simple maintenance, long-lasting life, non-defect top folding, top inserting, high production, and uniform bag making, are well reputed by customers.
 5. The machine greatly improves production efficiency while saving a lot of labors. It is widely applicable to printing and packaging enterprises of different scales or business types.
 6. Configured with remote control, easy to operate, friendly to starters, and easy to handle with and even unmanned operation.



参数示意图 Sheet Paper Data

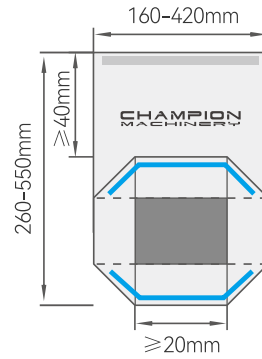
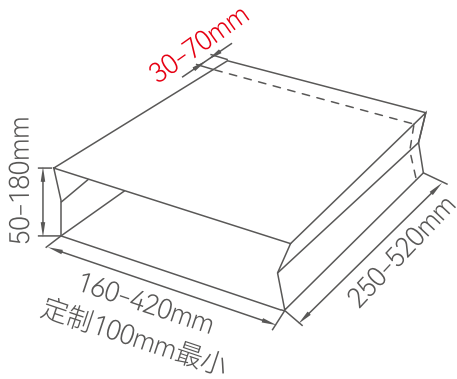
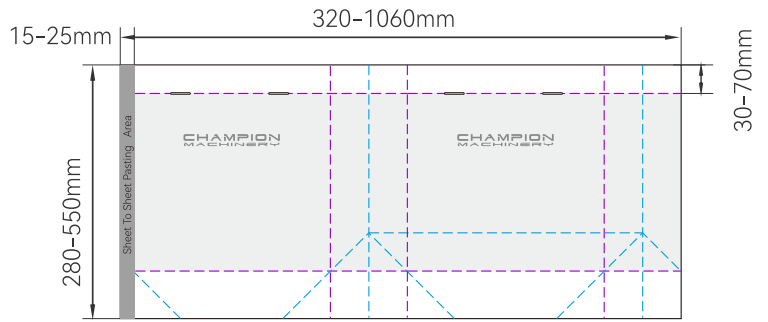
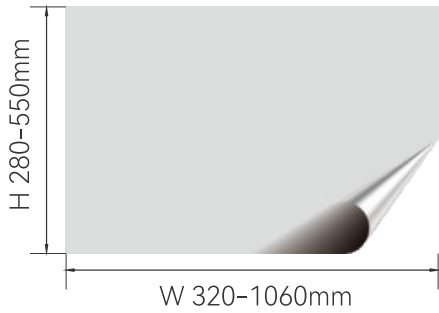

Type Bag Bottom (1)

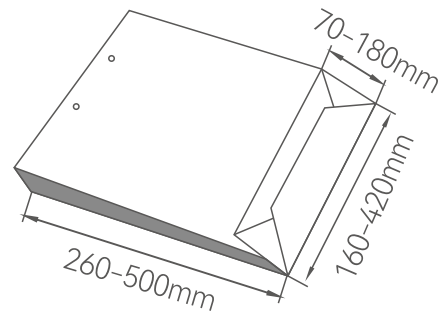
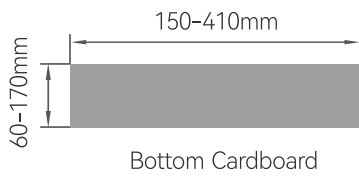



主要技术参数 TechnicalData

纸张尺寸 Sheet Paper Size		
W进纸宽度范围	Sheet Paper Width	320-1060mm
H进纸长度范围	Sheet Paper Length	280-550mm
纸筒尺寸 Paper Bag Tube Size		
折袋口尺寸	Paper Bag Top Folder Depth	30-70mm
纸筒宽度	Paper Bag Tube Width	160-420mm Customized Min 100mm
纸筒长度	Paper Bag Tube Length	250-520mm
风琴尺寸	Paper Bag Gusset	70-180mm
粘位尺寸	Sheet Paper Glue Side	15-25mm
适用纸张原材料和耗材 Suitable Paper Material & Glue & Handle		
牛皮纸	Kraft Paper	120-350gsm
铜版纸/覆膜纸	Coat Paper / Laminated	128-250gsm
白卡纸	White Board Paper	157-300gsm
灰板纸	Grey Board Paper	128-300gsm
胶水	Glue	标配热熔选配胶水溶性冷胶 Hot melt glue option water base glue
手提绳	Handle	纸手腕圆/扁, 贴丝带, 打头手提绳子/丝带 其他 Flat paper handle, twisted paper handle, tipping with rope or ribbon handle, Ribbon handles with top cardboard pasting glue fix of luxury paper bag
底卡 Bottom Cardboards		自动 Auto
底卡宽度	Bottom Cardboards Width	60-170mm
底卡长度	Bottom Cardboards Length	150-410mm
底卡克重	Bottom Cardboards Thickness	200-500gsm
运行 Running		
速度	Speed	0-80 pcs/min
安装要求 Installation		
装机总功率	Total Power Supply	17.5KW
压缩空气	Compressed Air / Capacity	6bar
储气罐能量	Air Tank Capacity	15m³/h



设备占地规划 Machine Floor Plan

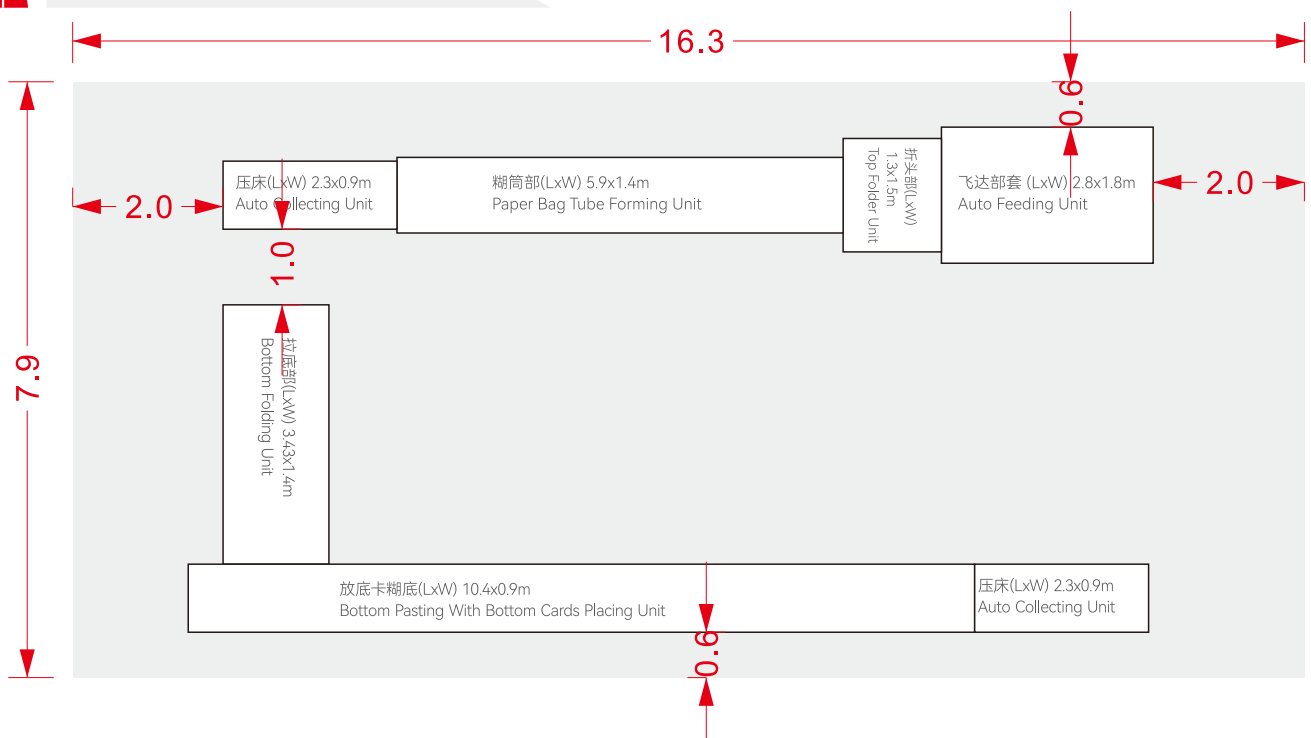



核心配件 Core Accessories



SynMatic

运动控制系统
伺服电机/伺服驱动/变频器
SIMOTION
Servo motor/servo drive/frequency converter

安驰 中国
SynMatic China



SynMatic

总线控制
BUS CONTROL

安驰 中国
SynMatic China



FOTEK

编码器/接近开关
热过载继电器接触器
ENCODER/PROXIMITY SWITCH
Thermal overload relay contactor

阳明 台湾
FOTEK Taiwan



KEYENCE

主光电眼/光纤
MAIN OPTICAL EYE/FIBER

基恩士 日本
Keyence Japan



繁易
FLEXEM

触摸屏
TOUCH SCREEN

繁易 中国
FLEXEM China



亞德客
AirTAC

电磁阀
SOLENOID VALVE

亚德客 台湾
AirTAC Taiwan



CPG

减速机马达
REDUCER MOTOR

晟邦 台湾
Shengbang CPG Taiwan



SIEMENS

主马达
MAIN MOTOR

茵梦达 德国
Innomotics Germany



ORION

真空泵
VACUUM PUMP

好利旺 日本
ORION Japan