

A0
Version

CHAMPION
MACHINERY

MACHINERY MANUFACTURER OF **LUXURY PAPER BAGS**
CHAMPION MACHINERY MANUFACTURING CO.,LTD.



Tel: +86 139 2586 8276
WhatsApp: +86 139 2586 8276



E-mail: Bel@championbagmaker.com
Website: www.paper-bag-machine.com



Add: 42#2and Longyan Industrial Avenue, Humen Town
Dongguan City, China PR

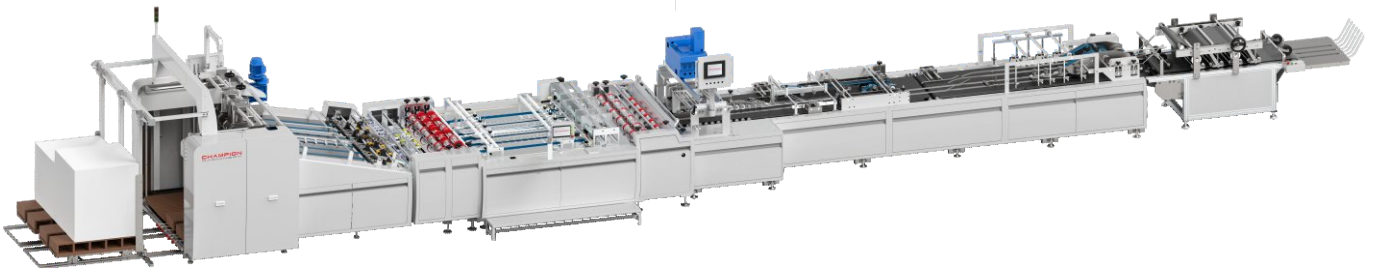

CM2SP-1400TF/1600TF

Automatic Paper Bag Double Sheets Pasting
With Tube Forming Machine

自动双拼纸袋糊筒机

目录

Contents

机器名称图片 Machine Name Image	3
工艺流程图 Process Flowchart	3
机器说明 Machine Description	4
机器特点 Machine Features	4
参数示意图 Sheet Paper Data	5
主要技术参数 Technical Data	6
设备占地规划 Machine Floor Plan	6
核心配件 Core Accessories	7

CM2SP-1400TF/1600TF

Automatic Paper Bag Double Sheets Pasting With Tube Forming Machine

自动双拼纸袋糊筒机

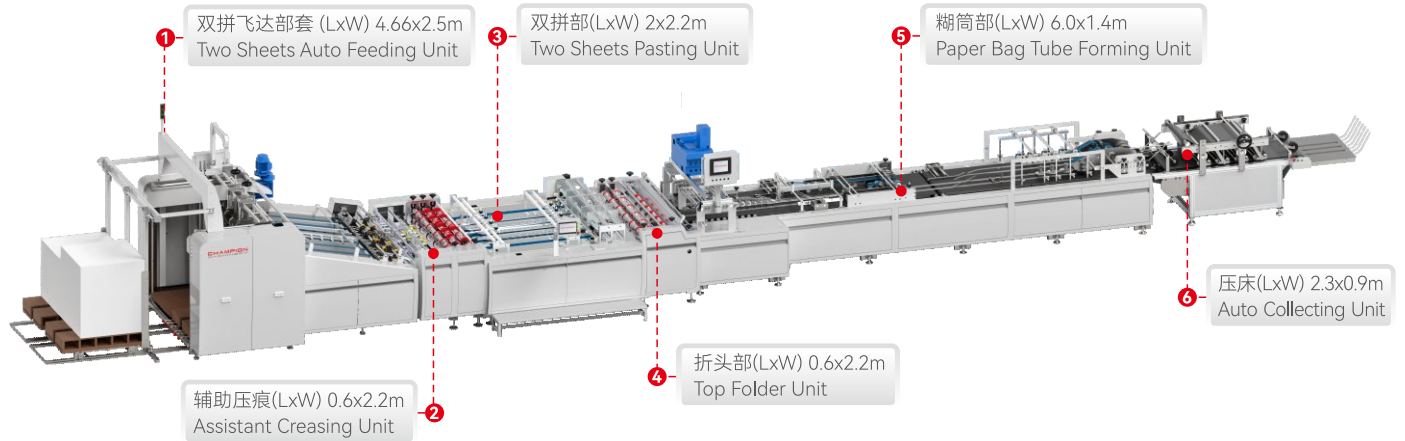

工艺流程图 Process Flowchart

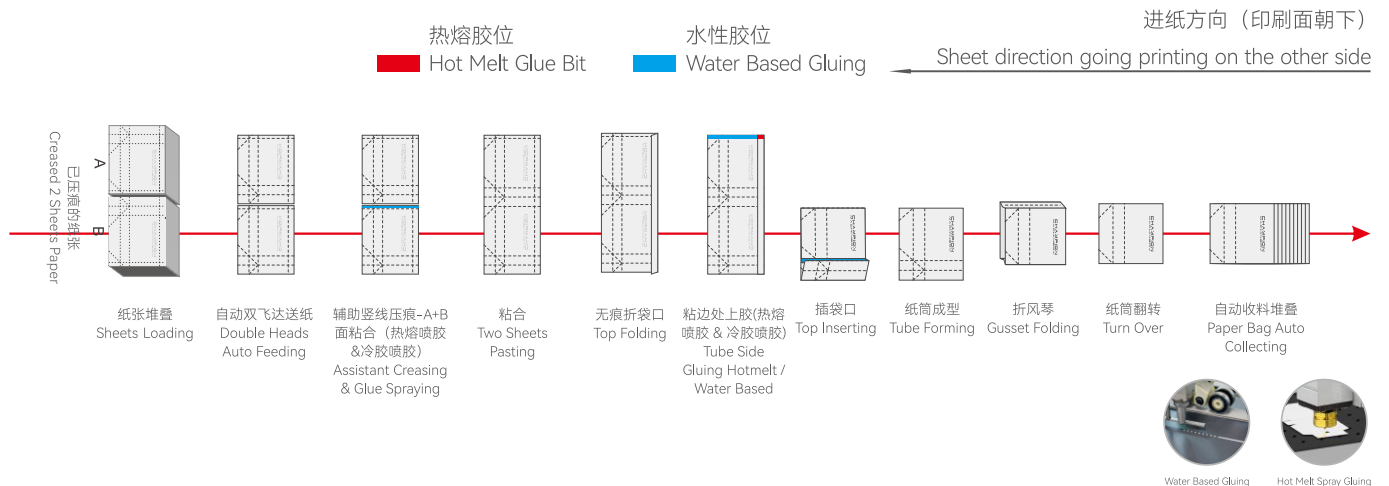



机器说明 Machine Description

该设备为自动双拼糊筒机，是一款集高效自动化的纸袋糊筒生产设备，专为满足双拼结构纸袋糊筒的生产需求而设计。该设备凭借其广泛的应用领域，如奢侈品、服装、礼品及购物纸袋等，展现了强大的市场适应性。

通过采用双拼成型技术，高速、高精度生产工艺以及智能化控制系统，实现降低成本、提升效率和优化质量。其模块化设计理念使得设备能够灵活应对不同生产需求，同时环保特性也符合当前绿色生产的趋势，成为传统纸袋生产设备升级换代的首选方案。

This automatic double-joint tube gluing machine is a highly efficient and automated paper bag tube gluing machine designed specifically to meet the production needs of double-joint structure paper bags. This machine demonstrates strong market adaptability through its wide range of applications, including luxury goods, clothing, gifts, and shopping paper bags.

By utilizing double-joint forming technology, high-speed, high-precision production processes, and an intelligent control system, it reduces costs, improves efficiency, and optimizes quality. Its modular design allows for flexible adaptation to diverse production needs. Its environmentally friendly features align with current trends in green production, making it a leading upgrade option for traditional paper bag production equipment.



机器特点 Machine Features

- 1. 拼接技术:** 采用自主研发的双拼技术，确保纸袋尺寸精准，成型良好。可将两张较小尺寸的纸袋拼接成一个大尺寸的纸袋，无需额外购买大型设备和材料，大幅降低生产成本和投资。
 - 2. 高效自动化:** 该设备实现了全自动化纸袋糊筒，从原材料到纸袋糊筒一次性完成生产过程，包括自动拼袋、成筒、折风琴。
 - 3. 智能控制:** 主控电路采用进口单片机，人机界面，变频控制，参数设定方便快捷，操作集中直观，完全实现人性化的全自动运行控制。数字化故障自诊断功能，故障诊断一目了然，方便快速维护和调整。
 - 4. 降低人工成本:** 自动化程度高，只需一人即可完成整个生产流程，可减少3-5人的人工成本及中间搬运环节。简单易学，节省人工成本，更加人性化。
 - 5. 耐用维护便捷:** 双变频设计，机械结构简洁，磨损小，维护方便，使用寿命长。
 - 6. 关键部件:** 整机核心部件均采用知名品牌，性能稳定、高效耐用。
 - 7. 环保材料:** 粘合工艺多采用环保水性胶和热熔胶，符合食品包装安全标准，设备结构便于清洁维护，减少废弃物产生。
 - 8. 材料适应:** 支持多种纸张材质（120-350g/m²），包括牛皮纸、白卡纸、铜版纸等。
- 1. Splicing Technology:** Utilizing independently developed double-splicing technology, the machine ensures precise paper bag dimensions and precise shaping. It can splice two smaller paper bags into one large one, eliminating the need for additional large-scale equipment and materials, significantly reducing production costs and investment.
 - 2. Efficient Automation:** The equipment realizes fully automated paper bag tube gluing, completing the production process from raw materials to paper bag tube gluing in one go, including automatic bag splicing, tube forming, accordion folding.
 - 3. Intelligent Control:** The main control circuit utilizes an imported single-chip microcomputer, a human-machine interface, and variable frequency control. Parameter setting is quick and easy, and operation is centralized and intuitive, achieving fully user-friendly, fully automatic operation. Digital fault self-diagnosis provides clear fault diagnosis at a glance, facilitating quick and easy maintenance and adjustments.
 - 4. Reduced Labor Costs:** With a high degree of automation, the entire production process can be completed by only one person, eliminating 3-5 labor costs and intermediate handling steps. Easy to learn, it saves labor costs and offers a more user-friendly experience.
 - 5. Durability and Easy Maintenance:** The dual-frequency design features a simple mechanical structure, minimal wear, easy maintenance, and a long service life.
 - 6. Key Components:** All core components of the entire machine utilize renowned brands, ensuring stable performance, high efficiency, and exceptional durability.
 - 7. Environmentally Friendly Materials:** The bonding process primarily utilizes environmentally friendly water-based and hot-melt adhesives, meeting food packaging safety standards. The machine structure is easy to clean and maintain, reducing waste generation.
 - 8. Material Compatibility:** Supports a variety of paper materials (120-350g/m²), including kraft paper, white cardboard, and coated paper.



参数示意图 Sheet Paper Data

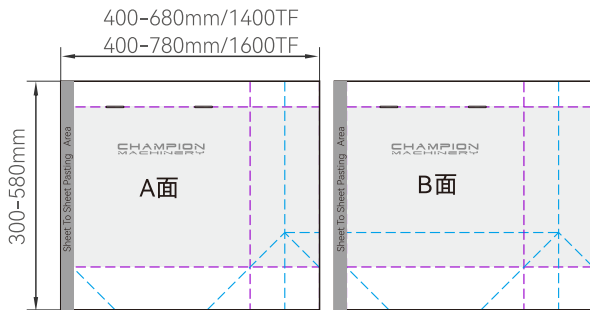
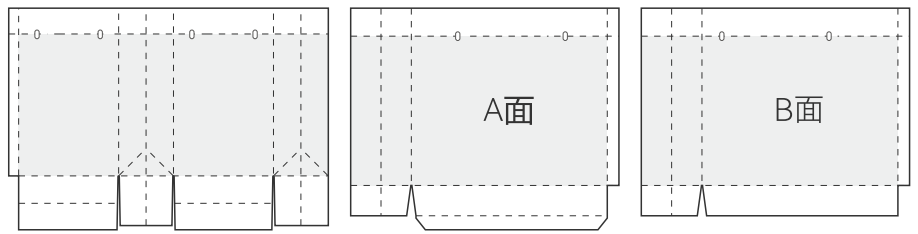
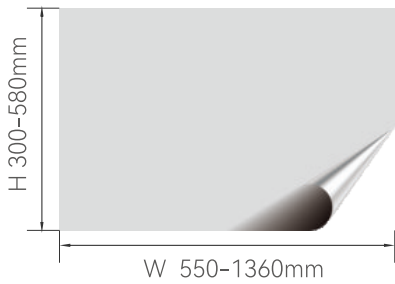

Before Pasting

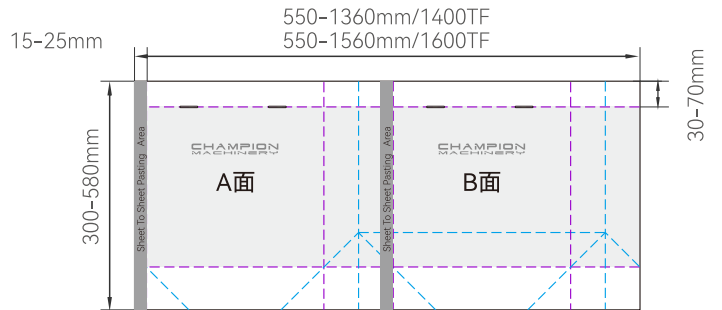

After Pasting

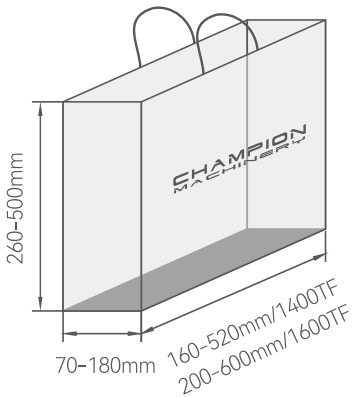

Paper Bag

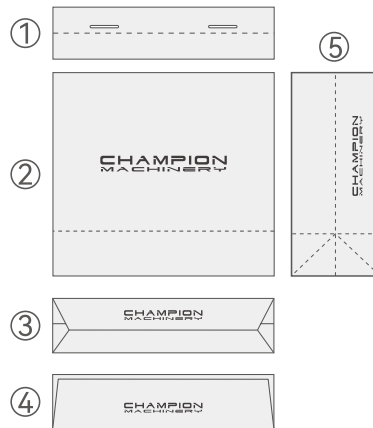
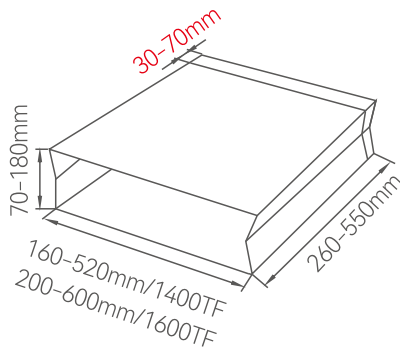

- 1、袋口折线位置
Bag opening fold line position
- 2、纸袋
Paper bag body
- 3、纸袋底型 (1)
Paper bag bottom type
- 4、纸袋底型 (2)
Paper bag bottom type
- 5、纸袋风琴
Paper bag gusset



主要技术参数 TechnicalData

纸张尺寸 Sheet Paper Size			
W进纸宽度范围	Sheet Paper Width	550-1360mm/1400TF	550-1560mm/1600TF
H进纸长度范围	Sheet Paper Length	300-580mm	
双拼纸尺寸 Two Sheet Paper Size			
W1进纸宽度范围	Before Pasting Sheet Paper Width 1	400-680mm/1400TF	400-780mm/1600TF
W2进纸宽度范围	Before Pasting Sheet Paper Width 2	400-680mm/1400TF	400-780mm/1600TF
纸筒尺寸 Paper Bag Tube Size			
折袋口尺寸	Paper Bag Top Folder Depth	30-70mm	
纸筒宽度	Paper Bag Tube Width	160-520mm/1400TF	200-600mm/1600TF
纸筒长度	Paper Bag Tube Length	260-550mm	
风琴尺寸	Paper Bag Gusset	70-180mm	
粘位尺寸	Sheet Paper Glue Side	15-25mm	
适用纸张原材料和耗材 Suitable Paper Material & Glue & Handle			
牛皮纸	Kraft Paper	120-350gsm	
铜版纸/覆膜纸	Coat Paper / Laminated	127-250gsm	
白卡纸	White Board Paper	157-300gsm	
灰板纸	Grey Board Paper	128-300gsm	
胶水	Glue	标配热熔选配胶水溶性冷胶 Hot melt glue option water base glue	
手提绳	Handle	纸手腕圆/扁, 贴丝带, 打头手提绳子/丝带 其他 Flat paper handle, twisted paper handle, tipping with rope or ribbon handle, Ribbon handles with top cardboard pasting glue fix of luxury paper bag	
运行 Running			
速度	Speed	0-60 pcs/min	
电压	Voltage	380V/220V 50/60HZ 3 phase	
生产功率	Production Power	15KW	
机器尺寸和重量 Machine Size & Weight			
机器	Size	16.2×2.55×1.9M	
重量	Weight	15000kg	
安装要求 Installation			
装机总功率	Total Power Supply	25KW	
压缩空气	Compressed Air / Capacity	6bar	
储气罐能量	Air Tank Capacity	15m³/h	



设备占地规划 Machine Floor Plan

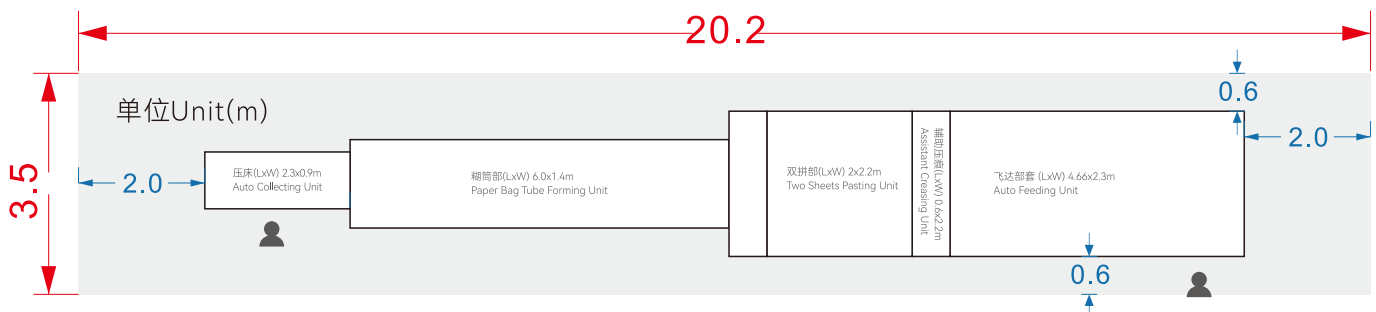



核心配件 Core Accessories



SynMatic

运动控制系统
伺服电机/伺服驱动/变频器
SIMOTION
Servo motor/servo drive/frequency converter

安驰 中国
SynMatic China



SynMatic

总线控制
BUS CONTROL

安驰 中国
SynMatic China



FOTEK

编码器/接近开关
热过载继电器接触器
ENCODER/PROXIMITY SWITCH
Thermal overload relay contactor

阳明 台湾
FOTEK Taiwan



KEYENCE

主光电眼/光纤
MAIN OPTICAL EYE/FIBER

基恩士 日本
Keyence Japan



繁易
FLEXEM

触摸屏
TOUCH SCREEN

繁易 中国
FLEXEM China



亞德客
AirTAC

电磁阀
SOLENOID VALVE

亚德客 台湾
AirTAC Taiwan



CPG

减速机马达
REDUCER MOTOR

晟邦 台湾
Shengbang CPG Taiwan



SIEMENS

主马达
MAIN MOTOR

茵梦达 德国
Innomotics Germany



ORION

真空泵
VACUUM PUMP

好利旺 日本
ORION Japan