

A0
Version

CHAMPION
MACHINERY

MACHINERY MANUFACTURER OF **LUXURY PAPER BAGS**
CHAMPION MACHINERY MANUFACTURING CO.,LTD.



Tel: +86 139 2586 8276
WhatsApp: +86 139 2586 8276



E-mail: Bel@championbagmaker.com
Website: www.paper-bag-machine.com



Add: 42#2and Longyan Industrial Avenue, Humen Town
Dongguan City, China PR



CMFB-330

Square Bottom Roll-fed Paper Bag Machine (Without Handle)
方底卷筒纸袋机（不带提手）



4 Colors 1300mm Stack Flexo In-line Printing Machine
4色1300mm叠纸柔版联机印刷机

目录

Contents

机器名称图片 Machine Name Image	3
机器说明 Machine Description	3
适用范围 Bag Suitable	4
工艺流程图 Process Flowchart	4
参数示意图 Sheet Paper Data	4
主要技术参数 Technical Data	4
设备占地规划 Machine Floor Plan	5
核心部件 Core Components	6
4 Colors 1300mm Stack Flexo In-line Printing Machine	7
机器说明 Machine Description	7
主要技术参数 Technical Data	8
机器说明 Machine Description	9

CMFB-330

Square Bottom Roll-fed Paper Bag Machine (Without Handle) 方底卷筒纸袋机（不带提手）



机器说明 Machine Description

该机器专为生产无手柄方底纸袋而设计，以卷筒纸为原料，是快速生产各种尺寸纸袋的理想设备。该机器通过实现送纸、成型、切管和底部成型等工序的在线化，有效节省人工成本。配备的光电检测器可校正切割长度，确保切割精度。该机器可处理非常薄的纸张，并且生产速度非常快，因此特别适合食品行业应用。

This machine is designed to manufacture square bottom paper bags without handles from paper roll, and it is an ideal equipment for producing producing various sized paper bags fast. By implementing steps including paper feeding, tube forming, tube cutting and bottom forming inline, this machine can effectively save labor costs. The equipped photoelectric detector can correct cutting length, so as to ensure cutting precision. This machine can process very thin paper, as well as produce paper bags very fast, thus this machine is especially suitable for being applied in food industries.



适用范围 Bag Suitable

1. 采用威龙触摸屏人机界面，操作功能一目了然，操控便捷。
2. 采用日本原装三菱运动控制器，通过与光纤的集成，运行稳定。
3. 采用日本三菱伺服电机配合德国希克色标眼纠偏，精准跟踪印刷袋尺寸。
4. 原料上下料采用液压动态升降结构，放卷采用自动恒张力控制。
5. 原料纠偏采用无刷伺服电机，减少纸卷对位调整时间。

1. Using Willon touch screen man-machine interface, the operation function is clear at a glance, easy to control
2. Adopt the Japanese original Mitsubishi motion controller, through the integration with the optical fiber, operation stability
3. Japanese Mitsubishi servo motor with German Schick color standard eye correction, accurate tracking printing bag size
4. The raw material loading and unloading adopts hydraulic dynamic lifting structure, and the unwinding adopts automatic constant tension control.
5. The raw material correction adopts brushless servo motor to reduce the adjustment time of paper roll alignment.



工艺流程图 Process Flowchart

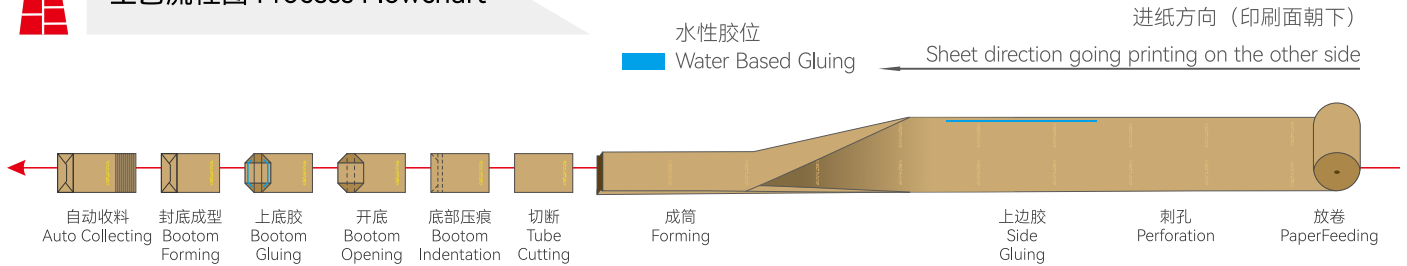

参数示意图 Sheet Paper Data

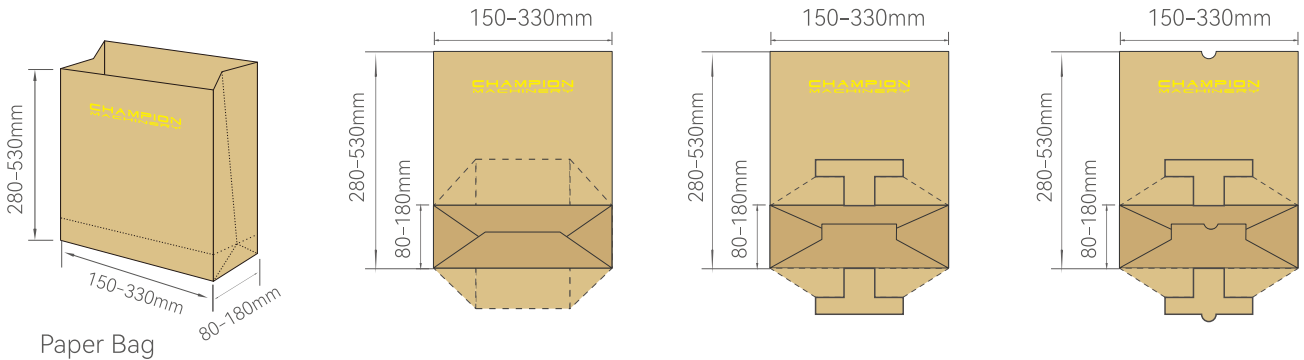

主要技术参数 Technical Data

纸袋部分 Paper bag part		
纸卷宽度	Paper roll width	490-1050mm
纸张直径	Paper Diameter	Φ1300mm (Max)
纸管直径	Paper core diameter	Φ76mm
纸张重量	Paper weight	80-140gsm
纸袋宽度	Paper bag Width	150-330mm
纸管长度	Paper tube Length	280-530mm
纸袋底部宽度	Bottom width of paper bag	80-180mm
运行速度 Running speed		
机器速度	Machine speed	200pcs/min
规格 Specification		
总功率	Total power	11KW
机器重量	Machine weight	8000KGS (40HQ*1)
机器尺寸	Machine Dimensions	9500 × 2600 × 1900mm

控制系统 Control System

名称	Name	数量 QTY	产地 Origina	品牌/Brand
运动控制器	Motion Controller	1	Japan	三菱 Mitsubishi
人机界面触摸屏	Human-computer touch screen interface	1	China	繁易 Flexem
印刷跟踪光电眼	Photoelectric eye for printed-bag tracking	2	Germany	西客 SICK
低压电器	Low voltage electrical apparatus	4	France	施耐德 Schneider Electric
光电传感器	Photoelectric sensor	10	Japan	松下 Panasonic
气动元件	Pneumatic component	18	Taiwan	亚德客 AirTAC
自动润滑油	Auto lubricating	1	China	
配电柜带自动恒温空调柜	Air conditioner for electric control box	1	China	
电源滤波器	Main power filter	1	China	
电机变频器	Motor frequency converter	2	Switzerland	ABB
伺服驱动器	Servo Motor	7	Japan	三菱 Mitsubishi
伺服电源	Servo Power	7	Japan	三菱 Mitsubishi
伺服电机减速机	Servo Motor Reducer	5	Japan	三菱 Mitsubishi

放卷纠偏、张力控制系统 Deviation correction and tension control system

名称	Name	数量 QTY	产地 Origina	品牌/Brand
纠偏控制器	EPC controller	3	China	恩瑞斯 Enris
伺服纠偏电机	Servo motor for EPC	3	China	恩瑞斯 Enris
超声波感应器	Ultrasonic sensor	3	China	恩瑞斯 Enris
磁粉制动器	Magnetic powder brake	3	China	中倍 Zhongbei
磁粉自动张力系统	Automatic Tension System of Magnetic Powder	3	China	中倍 Zhongbei
自动液压上料电机	Automatic Hydraulic Feeding Motor	1	China	顶铭 Inscription
上料液压油缸	Feeding hydraulic cylinder	2	China	顶铭 Inscription

传动 Transmission

名称	Name	数量 QTY	产地 Origina	品牌/Brand
同步带	Synchronous belt	10	China	巨隆 GILONG
同步轮	Synchronous wheel	13	China	巨隆 GILONG
轴承	Bearing	489	Japan	NSK
导辊	Guide roller	29	China	BAIXIAO
齿轮	Gear	76	China	

胶水部位 Glue position

名称	Name	数量 QTY	产地 Origina
底部胶 (糊底白乳胶)	Bottom glue (bottom-sealing white latex)	2	China
底部匀胶电机	Motor for bottom glue evening	1	China
自动气动灌胶阀	Pneumatic auto glue filling valve	1	Japan
边胶	Side glue	1	China
底胶胶位检测	Glue Glue Position Detection	1	China
中锋水性喷胶枪	Spraying gun for center sealing (dense adjust Glue gun)	1	China
水性白乳胶高压喷胶桶	High-pressure glue barrel for white latex	1	China



设备占地规划 Machine Floor Plan

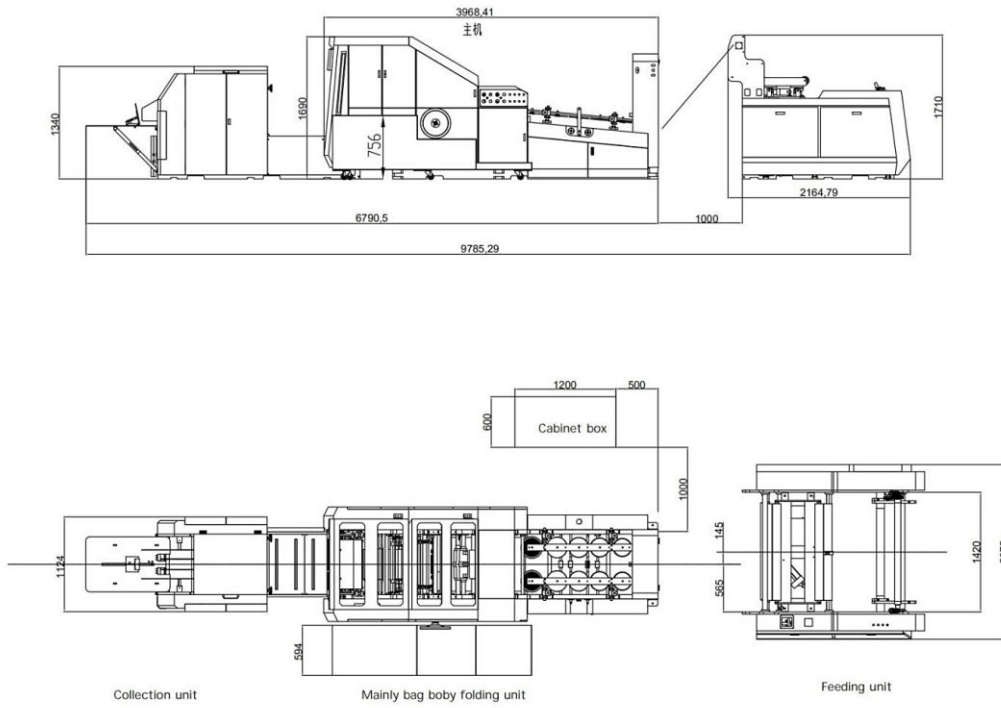

4 Colors 1300mm Stack Flexo In-line Printing Machine

4色1300mm叠纸柔版联机印刷机



机器说明 Machine Description

控制部分

1. 主电机变频调速，功率：
2. 减速电机独立控制

印刷部分

1. 气动升降印版滚筒，停机时自动升降印版滚筒，停机后自动供墨。
开机时，报警启动自动升降印版滚筒。
2. 采用陶瓷网纹刮刀供墨，墨泵循环供墨
3. 高精度行星齿轮箱，360°循环纵向套准
4. 横向套准±20mm
5. 手动调节墨量和印刷压力

干燥部分

1. 采用外置加热管，温度显示，电流控制，离心风机送风

CONTROL PART

1. Main motor frequency control, power:
2. Reduce motor separate

PRINTING PART

1. Pneumatic lifting and lowering printing plate cylinders auto lifting plate cylinder when the machine is stopped. After that can run ink automatically. When the machine is opening, it will make alarm to start the auto lowering plate printing cylinder.
2. Inking with ceramic anilox chambered doctor blade ,ink pump circulation
3. High precision planetary gear oven 360°circulation longitudinal register
4. ±20mm transverse register
5. Adjust inking press and printing pressure press by manual

DRYING PART

1. Adopt with external heating pipe, temperature display, electric current control, centrifugal blower bring the wind



主要技术参数 TechnicalData

进料宽度	Material Feeding Width	1000mm
最大印刷宽度	Max Printing Width	960mm
颜色	Colors	4Colors
材质	Material	paper
板材厚度	Thickness of plate	1.14mm.1.7mm 2.28mm.2.84mm. 3.94mm Customized is available
印刷速度	Printing speed	80-100m/min
套准精度	Register precision	±0.3mm



机器说明 Machine Description

1、传动装置

1套

皮带传动，精度高

Transmission

1 SET



2、4个印版滚筒

机器标准尺寸400mm

周长：280-1000mm

可定制

Plate roller 4Pcs

Standard 400mm for machine

Circumference: 280-1000mm

Can be customized.



3、陶瓷网纹辊

4根

均匀传墨

Ceramic anilox roller

4 Pcs

Transfer ink evenly

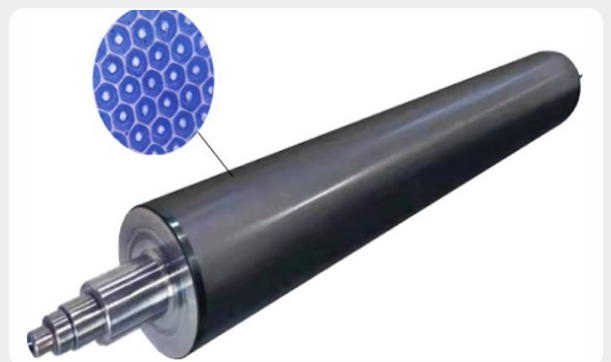

4、腔式刮墨刀

4套

1. 铝合金材质
2. 速度快，不溢墨
3. 密闭式设计，减少溶剂挥发



5、墨泵

4套

1. 自动循环系统
2. 双隔膜泵

Ink pump

4SETS

1. Automatic circle system
2. Double diaphragm pump

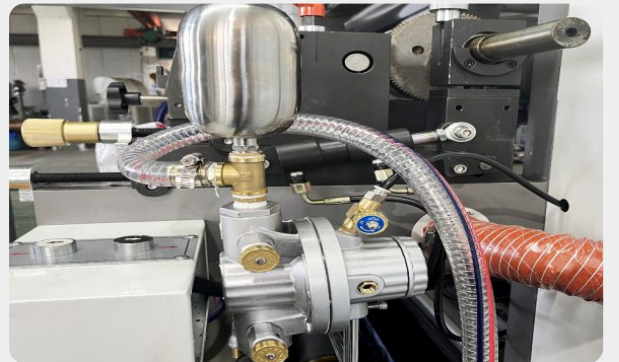

6、操作面板

1套

切换及各种参数设置

Operate panel

1SET

Switching and various parameter settings

