

**A0**  
Version

**CHAMPION**  
MACHINERY

MACHINERY MANUFACTURER OF **LUXURY PAPER BAGS**  
CHAMPION MACHINERY MANUFACTURING CO.,LTD.



Tel: +86 139 2586 8276  
WhatsApp: +86 139 2586 8276



E-mail: [Bel@championbagmaker.com](mailto:Bel@championbagmaker.com)  
Website: [www.paper-bag-machine.com](http://www.paper-bag-machine.com)



Add: 42#2and Longyan Industrial Avenue, Humen Town  
Dongguan City, China PR

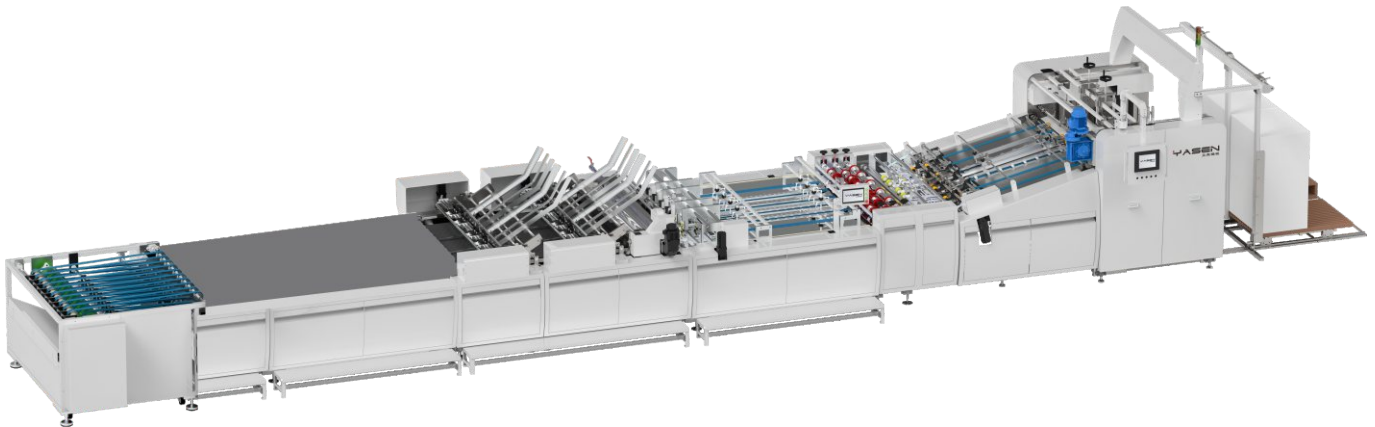

## **CM2SP-1400TCR/1600TCR**

Two Sheet Paper Pasting With 4pcs Top Cards + Ribbon Insert In

纸袋双拼贴头卡穿丝带机

# 目录

## Contents

机器名称图片 Machine Name Image	3
工艺流程图 Process Flowchart	3
机器说明 Machine Description	4
主要技术参数 Technical Data	4
设备占地规划 Machine Floor Plan	4
参数示意图 Sheet Paper Data	5
丝带款纸袋样式 Ribbon Paper Bag Style	6
袋头打孔样式 Bag Head Punching Style	6
丝带样式 Ribbon Style	7
核心配件 Core Accessories	8

# CM2SP-1400TCR/1600TCR

Two Sheet Paper Pasting With 4pcs Top Cards + Ribbon Insert In  
纸袋双拼贴头卡穿丝带机

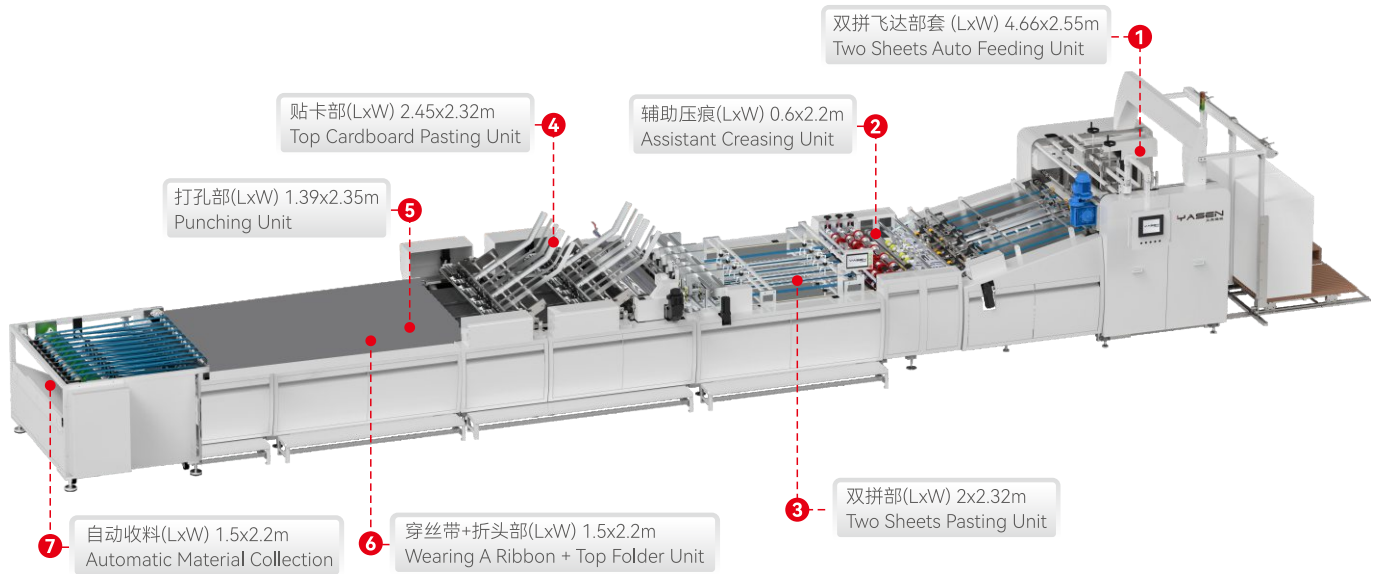

## 工艺流程图 Process Flowchart

头卡  
Top Cardboards

热熔胶位  
Hot Melt Glue Bit

水性胶位  
Water Based Gluing

进纸方向 (印刷面朝下)

Sheet direction going printing on the other side

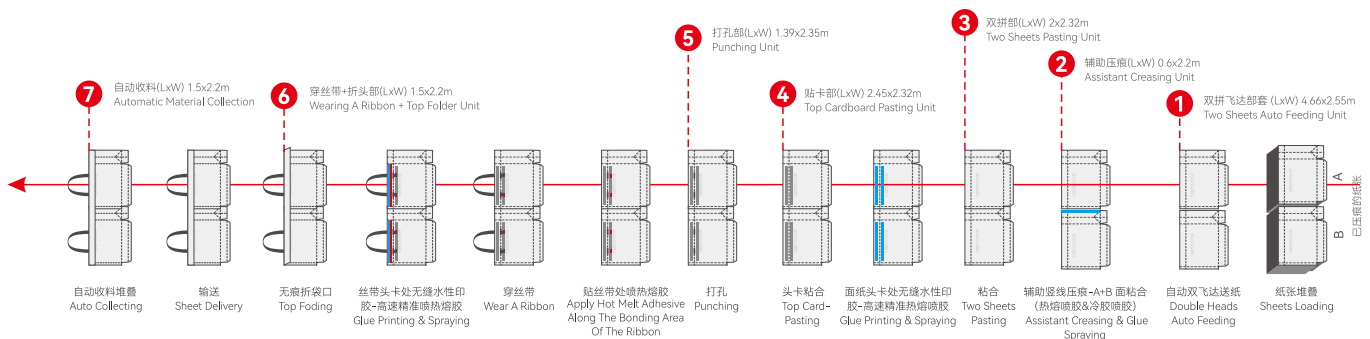





参数示意图 Sheet Paper Data

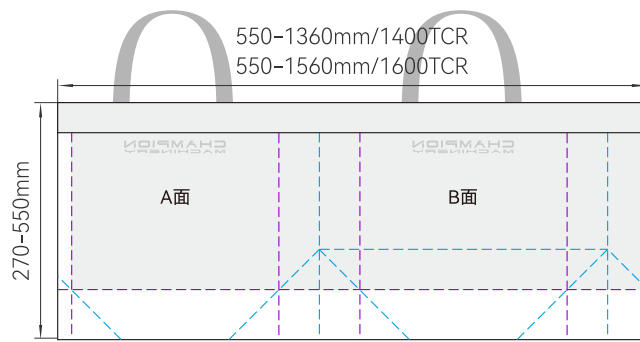
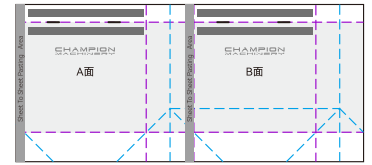
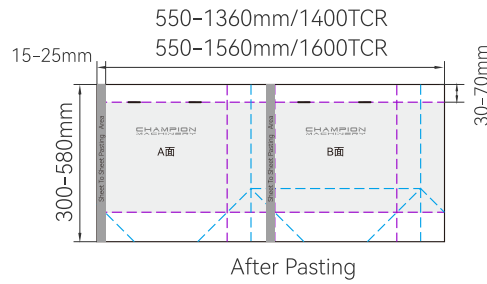
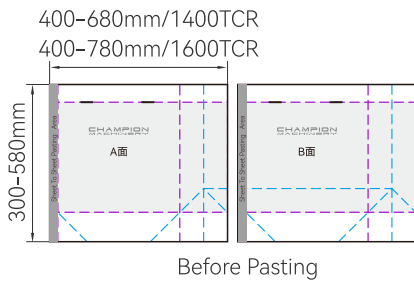
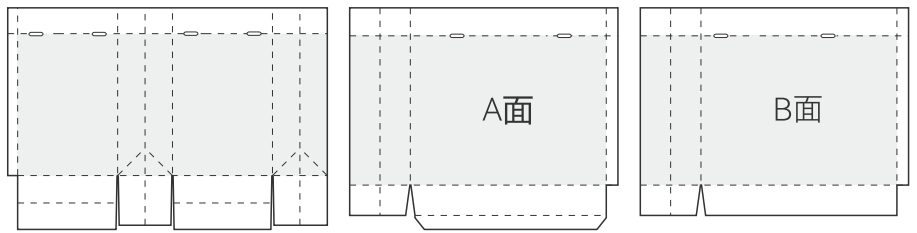
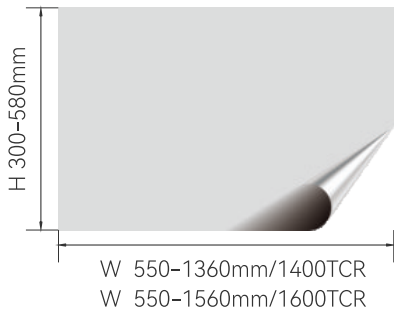

头卡粘贴的位置

Header card pasting position

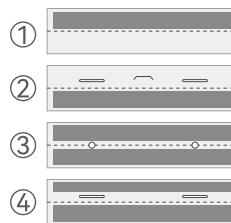
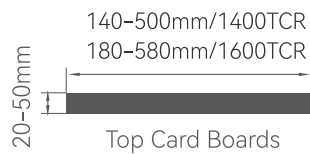

- 1、纸板高于折叠线的位置  
Position above top folding line
- 2、纸板位于折叠线以下  
Position below top folding line
- 3、顶部粘贴4张相同尺寸的纸板  
Top cardboard pasting 4 pcs same size
- 4、顶部粘贴4张不同尺寸的纸板  
Top cardboard pasting 4 pcs different size



丝带款纸袋样式 Ribbon Paper Bag Style

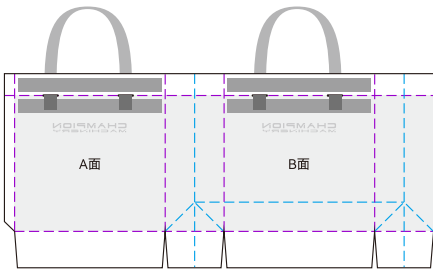

开花底方形孔丝带款  
Japanese Base With Square  
Hole And Ribbon Pattern

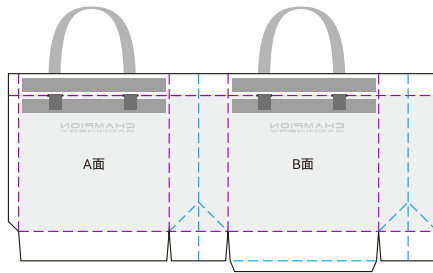

日本底椭圆孔丝带款  
Japanese Base With Oval  
Hole And Ribbon Pattern

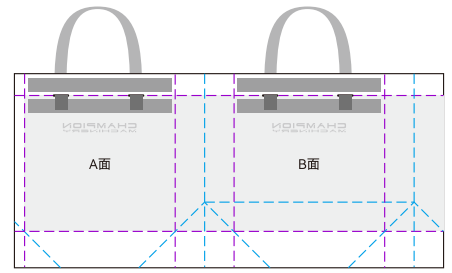

八字底方形孔丝带款  
Square Hole And Ribbon  
Pattern

织带宽度: 15-25mm  
织带长度: 400-600mm  
Handle Width: 15-25mm  
Handle Length: 400-600mm

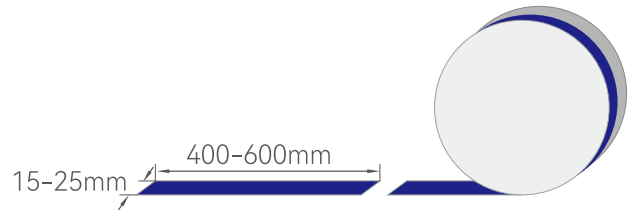

袋头打孔样式 Bag Head Punching Style

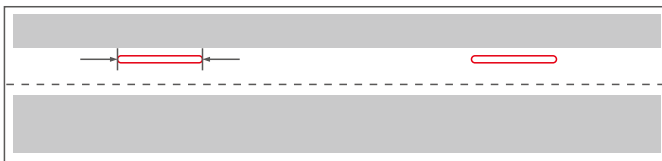

Size: 26mm x 3mm



Size: 26mm x 3mm

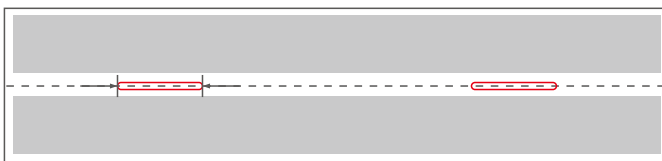

Size: 26mm x 3mm

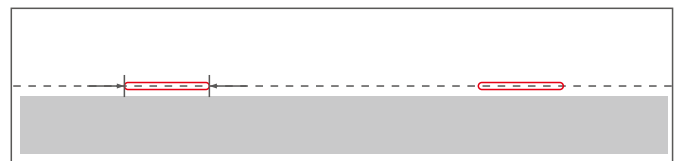

Size: 26mm x 3mm

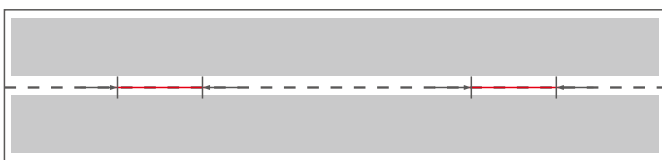

Size: 30mm



Size: 30mm



丝带样式 Ribbon Style

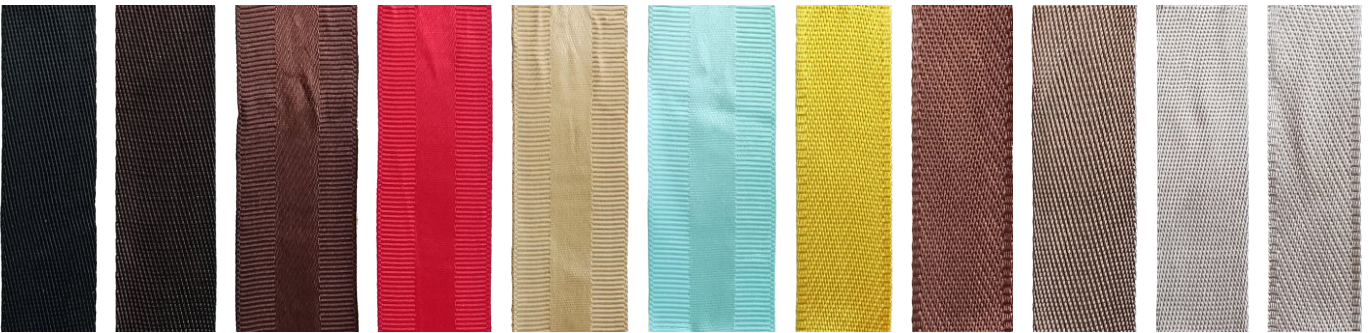



核心配件 Core Accessories



**SynMatic**

运动控制系统  
伺服电机/伺服驱动/变频器  
SIMOTION  
Servo motor/servo drive/frequency converter

安驰 中国  
SynMatic China



**SynMatic**

总线控制  
BUS CONTROL

安驰 中国  
SynMatic China



**FOTEK**

编码器/接近开关  
热过载继电器接触器  
ENCODER/PROXIMITY SWITCH  
Thermal overload relay contactor

阳明 台湾  
FOTEK Taiwan



**KEYENCE**

主光电眼/光纤  
MAIN OPTICAL EYE/FIBER

基恩士 日本  
Keyence Japan



**繁易**  
FLEXEM

触摸屏  
TOUCH SCREEN

繁易 中国  
FLEXEM China



**亞德客**  
AirTAC

电磁阀  
SOLENOID VALVE

亚德客 台湾  
AirTAC Taiwan



**CPG**

减速机马达  
REDUCER MOTOR

晟邦 台湾  
Shengbang CPG Taiwan



**SIEMENS**

主马达  
MAIN MOTOR

茵梦达 德国  
Innomotics Germany



**ORION**

真空泵  
VACUUM PUMP

好利旺 日本  
ORION Japan