

A0
Version

CHAMPION
MACHINERY

MACHINERY MANUFACTURER OF **LUXURY PAPER BAGS**
CHAMPION MACHINERY MANUFACTURING CO.,LTD.



Tel: +86 139 2586 8276
WhatsApp: +86 139 2586 8276



E-mail: Bel@championbagmaker.com
Website: www.paper-bag-machine.com



Add: 42#2and Longyan Industrial Avenue, Humen Town
Dongguan City, China PR

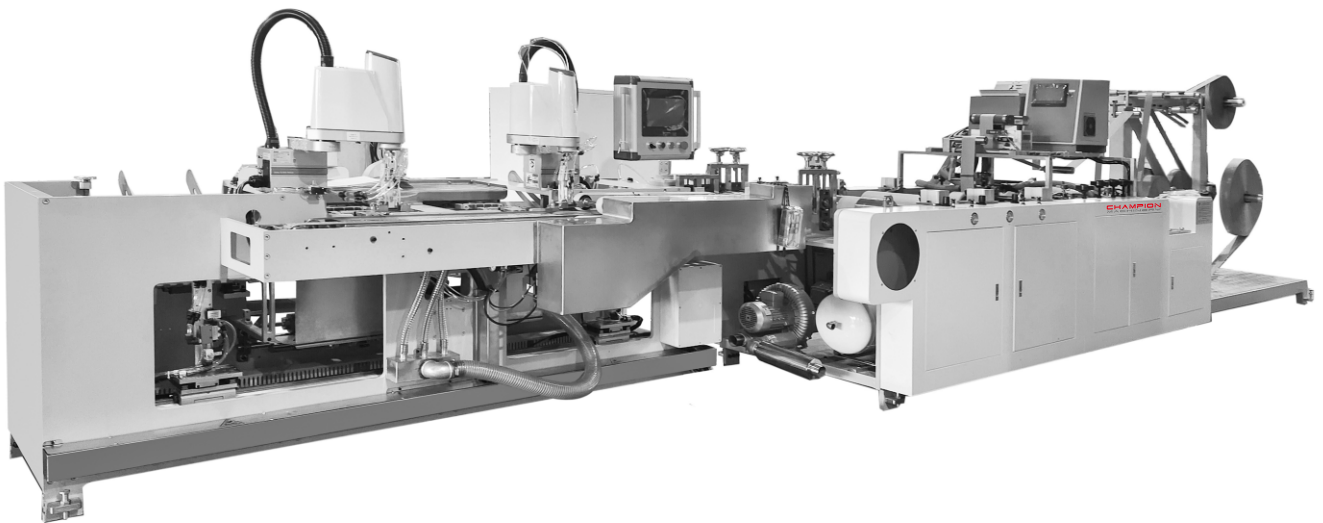

CMPS-350A

Paper Bag Angle Flat Paper Handle Pasting Inline With
Handle Making Machine-Double Robotic

纸袋扁绳自动贴手腕机——双机器人

目录

Contents

| | |
|---------------------------|---|
| 机器名称图片 Machine Name Image | 3 |
| 工艺流程图 Process Flowchart | 3 |
| 机器说明 Machine Description | 4 |
| 机器特点 Machine Features | 4 |
| 主要技术参数 Technical Data | 5 |
| 设备占地规划 Machine Floor Plan | 5 |

CMPS-350A

Paper Bag Angle Flat Paper Handle Pasting Inline
With Handle Making Machine-Double Robotic

纸袋扁绳自动贴手腕机——双机器人

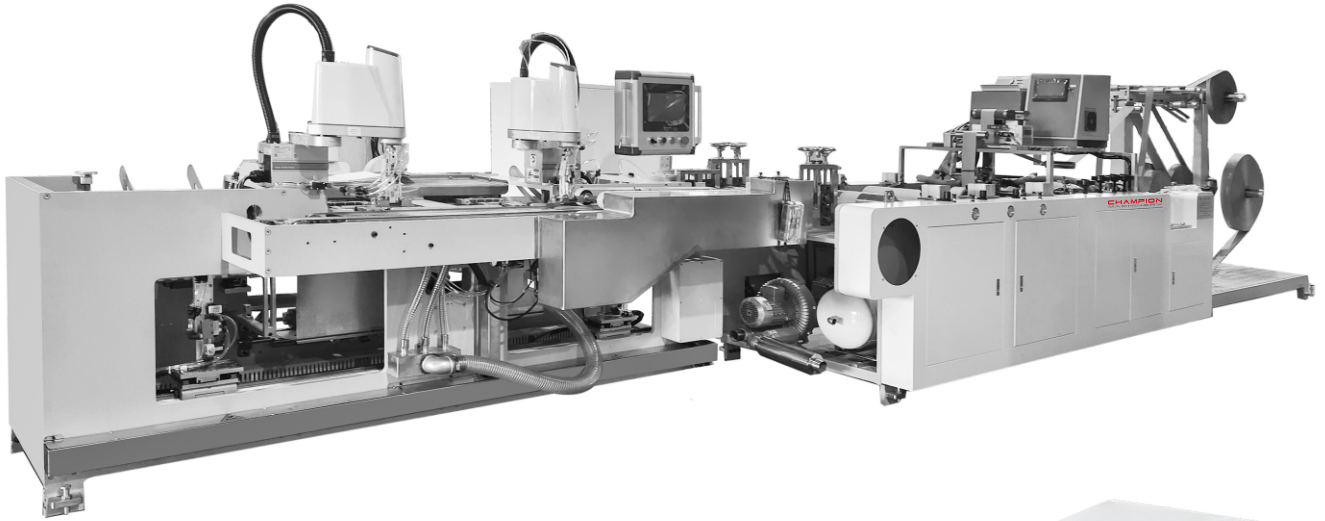

40 pcs

One minute 1分钟

Large size accordion
paper bag
大尺寸风琴纸袋

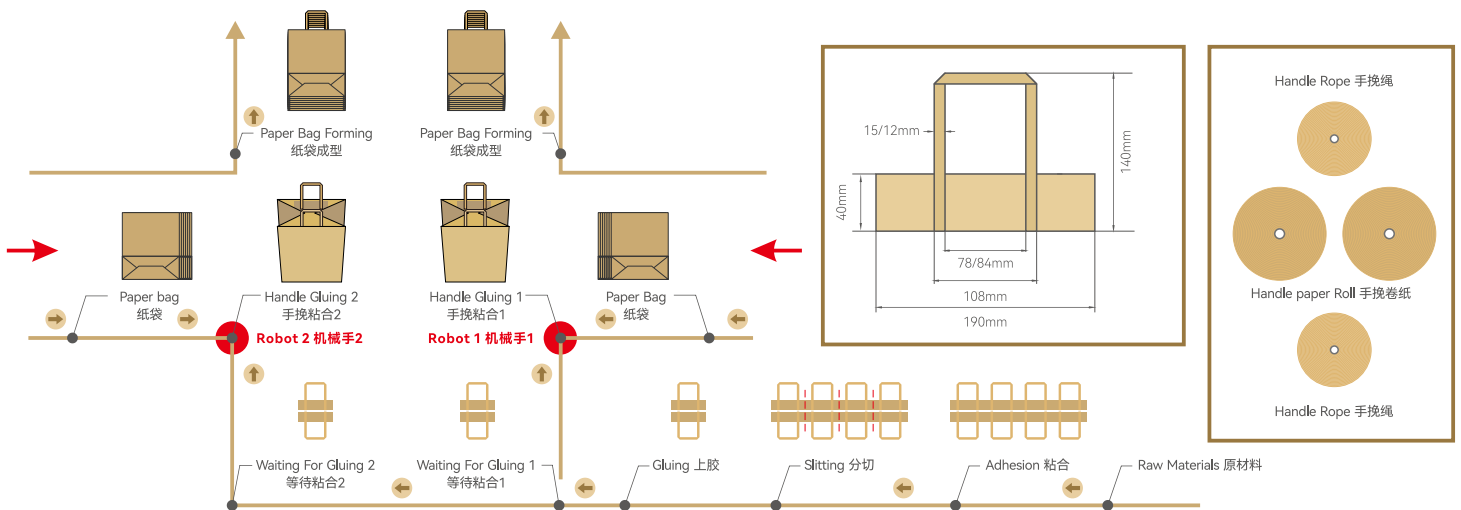
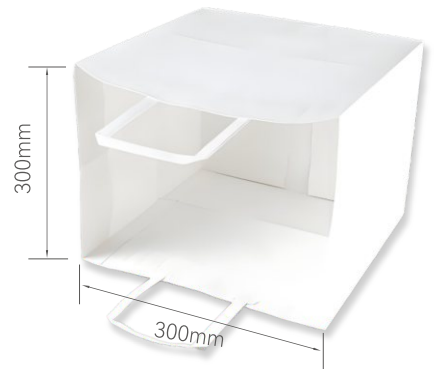

Double Robotics (Customized) 双机器人 (定制)



機器說明 Machine Description

这款双机械手圆绳贴把机配合半自动纸袋机使用，生产手挽跟粘合于一体。是我们单机械手贴把机的升级版，可以贴更小尺寸的纸袋，袋宽180-400mm，填补了全自动纸袋机不能生产小于200宽纸袋的空白。是您解决人工贴纸袋的不二选择。

该机器也有自动计数和自动上胶的功能，能极大地提高用户后续加工作业的效率。速度稳定，可达40个/分钟。

This 2 robot arm applicator designed to work with semi-automatic paper bag making machines, can produce flat rope handle with pasting inline. Its an upgraded model of 1 robot arm handle pasting machine, it works for smaller bag width sizes ranging from 180mm-400mm, thus filling the gap that the automatic paper bag machine can't produce bag width below 200mm. If you want to replace your labor by robot, this machine is your second to non choice.

The machine also has automatic counting and gluing functions, which can greatly improve the efficiency of the user's subsequent processing operations. The speed is stable and can reach 40 pieces per minute.



机器特点 Machine Features

生产速度: 40个/分钟（视扁绳材质与纸袋尺寸调整），支持连续化产线集成。

定位精度: 采用光学传感与伺服驱动系统，贴装位置误差 $\leq \pm 0.5\text{mm}$ ，避免手挽歪斜或脱胶。

速干胶粘合技术: 搭载台湾或德国进口胶黏系统，喷胶量可编程控制，确保扁绳与纸袋瞬间粘合且无溢胶。

自适应调节机构: 设备内置机械式间隙消除模块，兼容袋宽180-400mm、扁绳宽度12mm的规格。

人机交互界面: 配备触摸屏+PLC控制系统，集成参数预设、生产计数、故障自检（如缺绳/断胶报警）功能。

节能设计: 待机状态下自动降功耗，支持7×24小时连续运行。

模块化架构: 核心部件（送绳模块、胶枪、压合辊）采用快拆设计，维护便捷。

重型机身: 整机重量约2500kg，搭配进口线性导轨，抑制高速振动，延长使用寿命。

Production Speed: 40 pieces/minute (adjustable depending on the rope material and paper bag size), supporting continuous production line integration.

Positioning Accuracy: Utilizing an optical sensor and servo drive system, placement accuracy is $\leq \pm 0.5\text{mm}$, preventing misalignment or debonding.

Quick-drying Glue Bonding Technology: Equipped with an adhesive system imported from Taiwan or Germany, the adhesive spray volume is programmable, ensuring instant, overflow-free bonding of the rope and paper bag.

Adaptive Adjustment Mechanism: The machine features a built-in mechanical gap elimination module, compatible with bag widths of 180-400mm and rope widths of 12mm.

Human-Machine Interface: Equipped with a touchscreen + PLC control system, it integrates parameter presets, production counters, and fault self-diagnosis (such as rope shortage/glue breakage alarms).

Energy-saving Design: Automatically reduces power consumption in standby mode, supporting 24/7 operation.

Modular Architecture: Core components (rope feed module, glue gun, and lamination roller) feature quick-release design for easy maintenance. Heavy-duty body: The whole machine weighs about 2500kg and is equipped with imported linear guide rails to suppress high-speed vibration and extend service life.



主要技术参数 TechnicalData

| | | |
|---------|------------------------|------------------------|
| 外形尺寸 | Overall Dimension | L7800*W3500*H1800mm |
| 电机品牌 | Motor Brand | ZHENGMING geared motor |
| 机器功率 | Total Power | 380V, 23KW, 50HZ |
| 伺服电机品牌 | Servo Motor Brand | INOVANCE |
| 伺服电机功率 | Servo Motor Power | 400W two group |
| PIC编程品牌 | Pic Programming Brand | INOVANCE |
| 热熔胶机品牌 | Hot Melt Machine Brand | XBS |
| 机械手 | Mechanical Arm | DELTA Taiwan |
| 纠偏 | Correct An Error | KCON |
| 纸绳距离 | Handle Spacing | 108mm |
| 纸片长度 | Paper Length | 152mm |
| 纸绳宽度 | Paper Rope Width | 12mm |
| 纸片宽度 | Paper Width | 40mm |
| 纸绳高度 | Paper Rope Height | 100mm |
| 纸袋厚度 | Paper Thickness | 90-130g |
| 纸袋宽度 | Bag Width | 180-400mm |
| 纸袋高度 | Bag Height | 180-400mm |
| 纸袋侧宽 | Bag Side Width | 80-200mm |
| 袋高-底高 | Bag Height - Gusset | ≥ 25mm |
| 生产速度 | Production Speed | 37-43pcs/min |



设备占地规划 Machine Floor Plan

